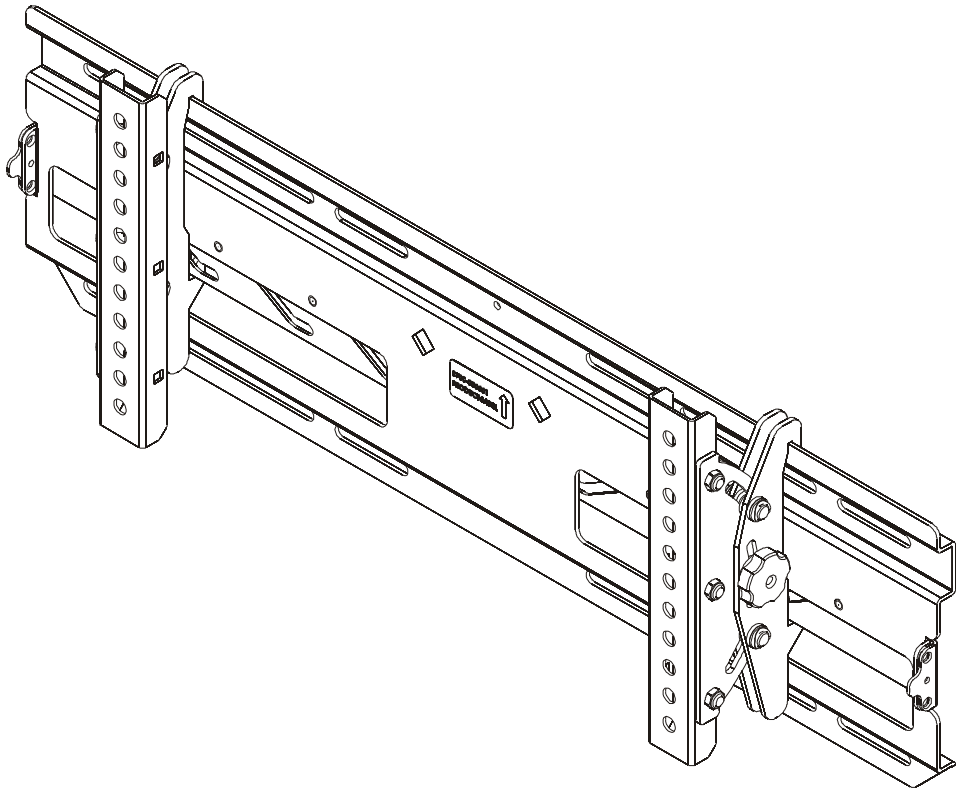


---

# INSTALLATION INSTRUCTIONS

---



---

**All-Weather Non-Articulating Wall Mount**

---

---

***SunBriteTV***<sup>®</sup>

---

**SB-WM46NA**

---

## DISCLAIMER

SunBriteTV LLC (SBTV) intend to make this manual accurate and complete. However, SBTV makes no claim that the information contained herein covers all details, conditions or variations, nor does it provide for every possible contingency in connection with the installation or use of this product. The information contained in this document is subject to change without notice or obligation of any kind. SBTV makes no representation of warranty, expressed or implied, regarding the information contained herein. SBTV assumes no responsibility for accuracy, completeness or sufficiency of the information contained in this document.

SunBriteTV® is a registered trademark of SunBrite TV LLC. Built to SunBriteTV® specifications by Chief Manufacturing. All rights reserved.



**WARNING:** Use this mounting system only for its intended use as described in these instructions. Do not use attachments not recommended by the manufacturer.



**WARNING:** Never operate this mounting system if it is damaged. Return the mounting system to a service center for examination and repair.

**IMPORTANT ! :** The SB-WM46NA mounts are designed to be mounted to a 2" x 4" wood studs (16" on center) wall.

**--SAVE THESE INSTRUCTIONS--**



## IMPORTANT SAFETY INSTRUCTIONS



**WARNING:** A WARNING alerts you to the possibility of serious injury or death if you do not follow the instructions.



**CAUTION:** A CAUTION alerts you to the possibility of damage or destruction of equipment if you do not follow the corresponding instructions.



**WARNING:** Failure to read, thoroughly understand, and follow all instructions can result in serious personal injury, damage to equipment, or voiding of factory warranty! It is the installer's responsibility to make sure all components are properly assembled and installed using the instructions provided.

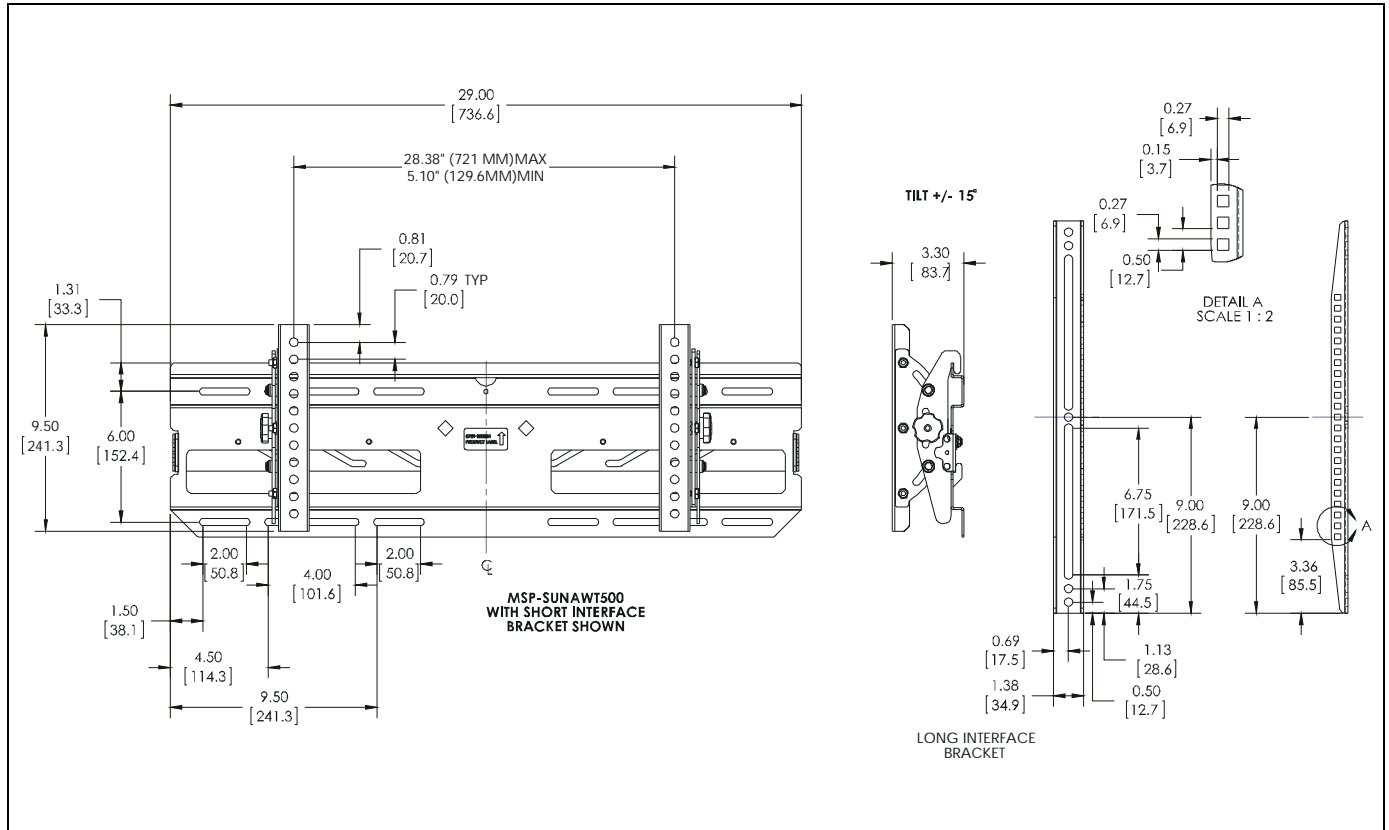


**WARNING:** Failure to provide adequate structural strength for this component can result in serious personal injury or damage to equipment! It is the installer's responsibility to make sure the structure to which this component is attached can support five times the combined weight of all equipment. Reinforce the structure as required before installing the component. The wall to which the mount is being attached may have a maximum drywall thickness of 5/8" (1.6cm). Do not install drywall anchors into the seam between drywall pieces.





**WARNING:** Exceeding the weight capacity can result in serious personal injury or damage to equipment! It is the installer's responsibility to make sure the combined weight of all components located between the SB-WM46NA up to (and including) the display does not exceed 175 lbs (80 kg).


**DIMENSIONS**




## LEGEND


	<b>Tighten Fastener</b>
	Apretar elemento de fijación
	Befestigungsteil festziehen
	Apertar fixador
	Serrare il fissaggio
	Bevestiging vastdraaien
Serrez les fixations	


	<b>Loosen Fastener</b>
	Aflojar elemento de fijación
	Befestigungsteil lösen
	Desapertar fixador
	Allentare il fissaggio
	Bevestiging losdraaien
Desserrez les fixations	


	<b>Phillips Screwdriver</b>
	Destornillador Phillips
	Kreuzschlitzschraubendreher
	Chave de fendas Phillips
	Cacciavite a stella
	Kruiskopschroevendraaier
Tournevis à pointe cruciforme	

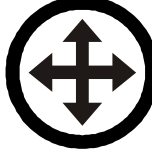
	<b>Open-Ended Wrench</b>
	Llave de boca
	Gabelschlüssel
	Chave de bocas
	Chiave a punte aperte
	Steeksleutel
Clé à fourche	


	<b>By Hand</b>
	A mano
	Von Hand
	Com a mão
	A mano
	Met de hand
À la main	


	<b>Hex-Head Wrench</b>
	Llave de cabeza hexagonal
	Sechskantschlüssel
	Chave de cabeça sextavada
	Chiave esagonale
	Zeskantsleutel
Clé à tête hexagonale	


	<b>Pencil Mark</b>
	Marcar con lápiz
	Stiftmarkierung
	Marcar com lápis
	Segno a matita
	Potloodmerkteken
Marquage au crayon	

	<b>Drill Hole</b>
	Perforar
	Bohrloch
	Fazer furo
	Praticare un foro
	Gat boren
Percez un trou	

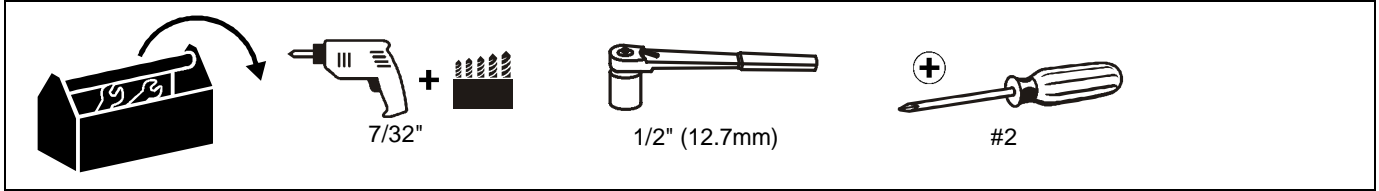
	<b>Adjust</b>
	Ajustar
	Einstellen
	Ajustar
	Regolare
	Afstellen
Ajuster	

	<b>Remove</b>
	Quitar
	Entfernen
	Remover
	Rimuovere
	Verwijderen
Retirez	

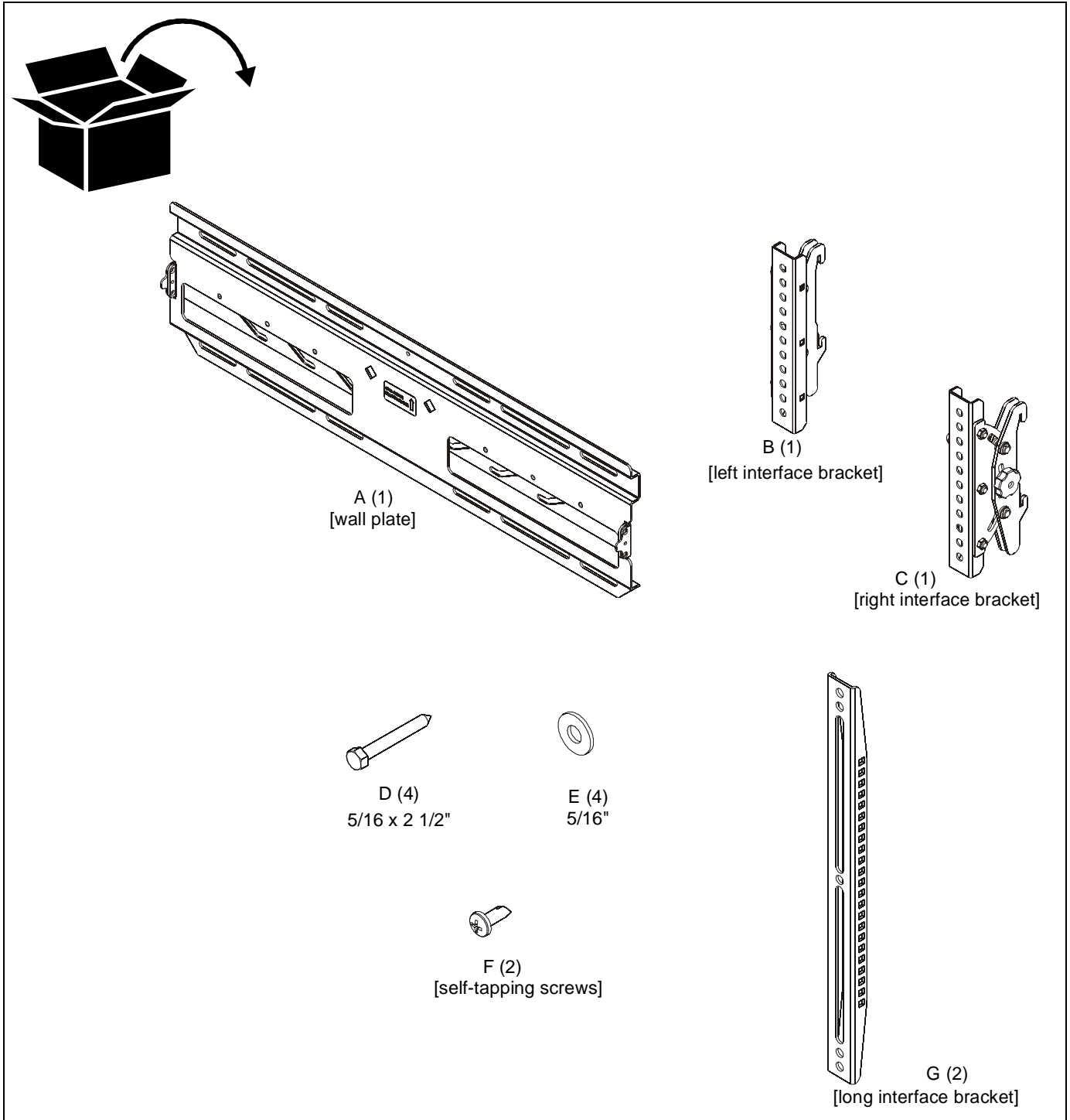
	<b>Optional</b>
	Opcional
	Optional
	Opcional
	Opzionale
	Optie
En option	

	<b>Security Wrench</b>
	Llave de seguridad
	Sicherheitsschlüssel
	Chave de segurança
	Chiave di sicurezza
	Veiligheidssleutel
Clé de sécurité	

### TOOLS REQUIRED FOR INSTALLATION



### PARTS



**ASSEMBLY and INSTALLATION**

**INSPECT MOUNT BEFORE ASSEMBLY**

1. Carefully inspect the mount components for shipping damage.
2. If any damage is apparent, call your carrier claims agent and do not continue with the installation until the carrier has reviewed the damage.

**NOTE:** Read all assembly instructions before starting the installation process.

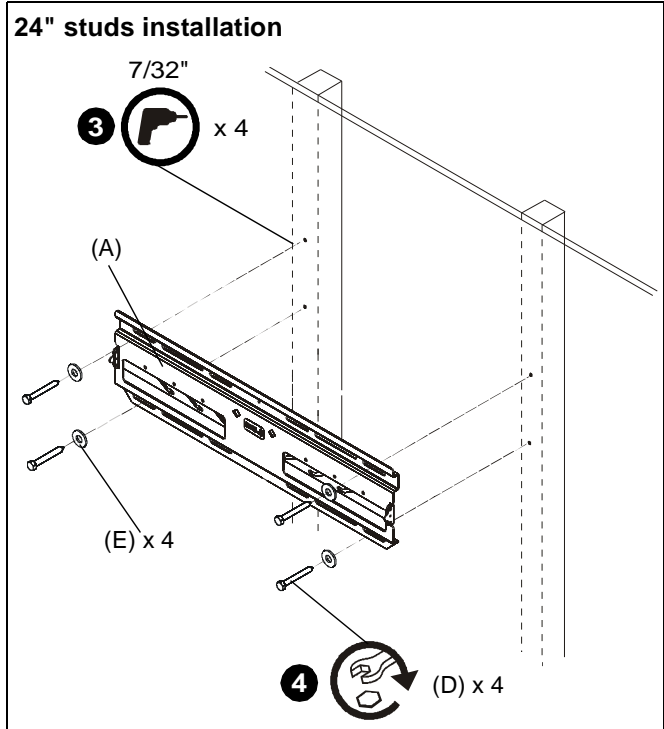
**Wall Plate Installation**

**IMPORTANT ! :** The SB-WM46NA mounts are designed to be mounted to a 2" x 4" wood studs (16" or 24" on center) wall.



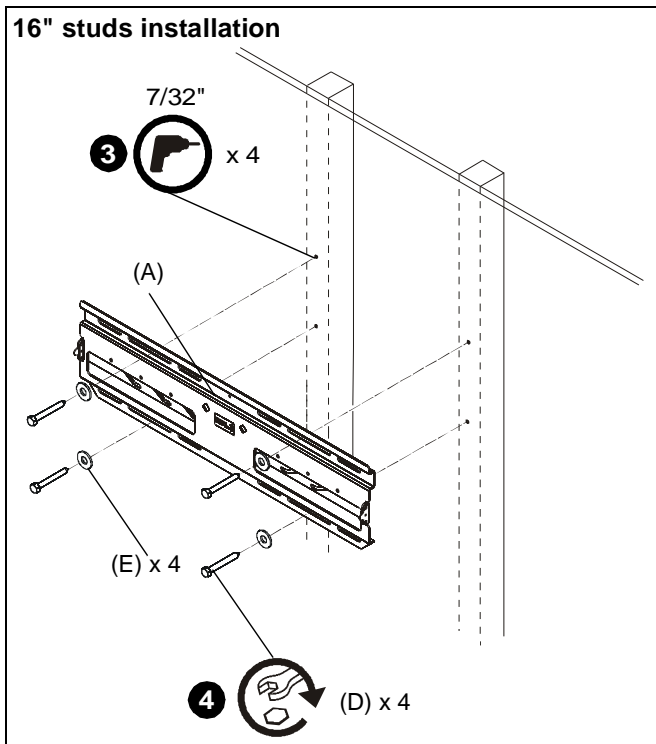
**WARNING:** It is the responsibility of the installer to verify that the structure to which the mount is anchored will safely support five times the combined load of all attached components and equipment.

1. Determine a suitable mounting location and lift the wall plate (A) into mounting position on wall.
2. Using a small nail or screw (not provided) in the center hole, lightly support the wall plate at the mounting location. (See Figure 1)
3. Level the wall plate (A) and drill 7/32" pilot holes for anchoring the wall plate. (See Figure 1)
4. Using four 5/16 x 2 1/2" lag bolts (D) and four 5/16" washers (E), install the wall plate on the wall. (See Figure 1) and (See Figure 2)

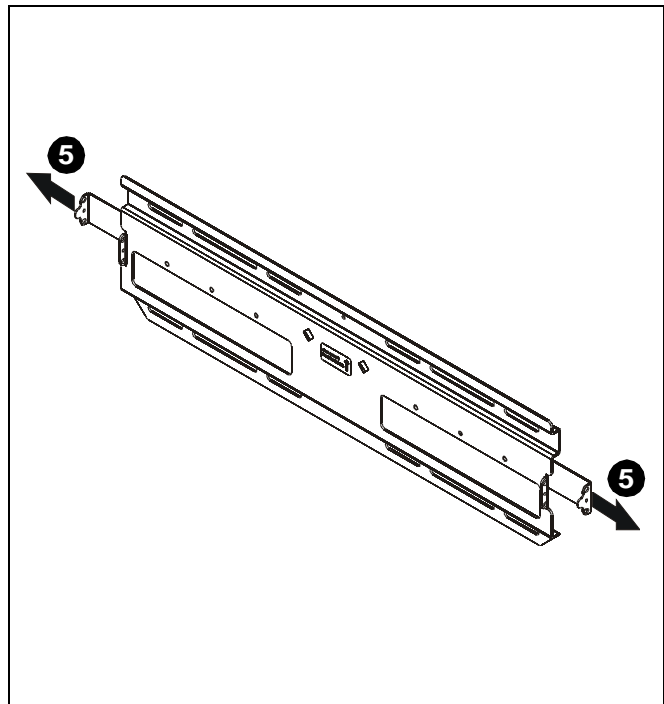


**Figure 2**

5. Slide the latches on the wall mount to the outside in preparation for installing display. (See Figure 3)



**Figure 1**



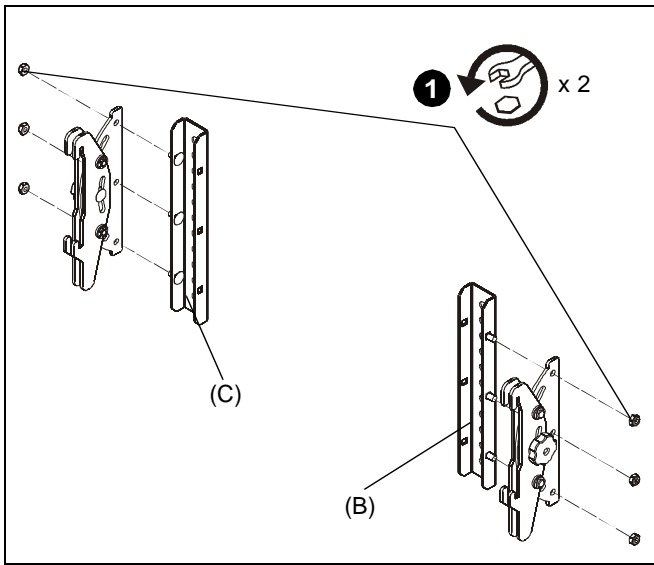
**Figure 3**

**Interface Bracket Installation**

**IMPORTANT ! :** Interface brackets (B and C) are shipped factory assembled to mount the SunBriteTV® 4600 and 5500-Series all-weather outdoor LCD televisions. If mounting a SunBriteTV® 6500-Series television, long interface brackets (G) must be installed to brackets prior to installing brackets to display.

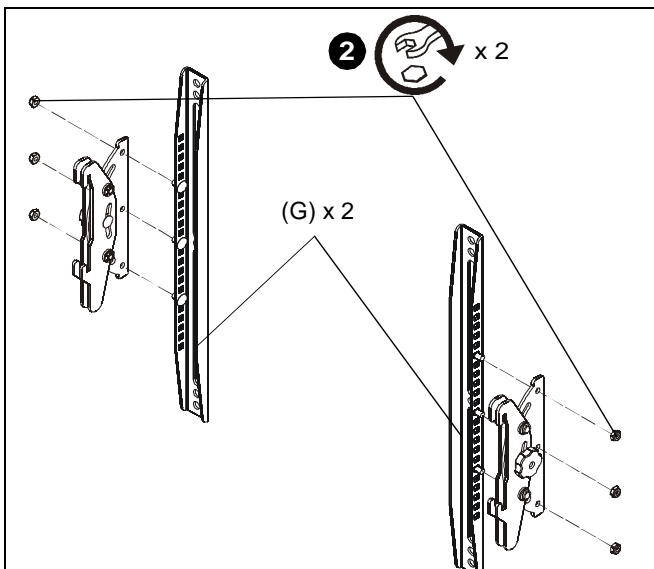
**Re-assembling Interface Brackets (6500-Series only)**

1. Remove hex nuts from interface brackets (B and C) to disassemble brackets. Set aside hardware and hanging brackets to be used in re-assembly. (See Figure 4)



**Figure 4**

2. Replace short interface brackets with long interface brackets (G) and re-assemble brackets using hex nuts and screws. (See Figure 5)



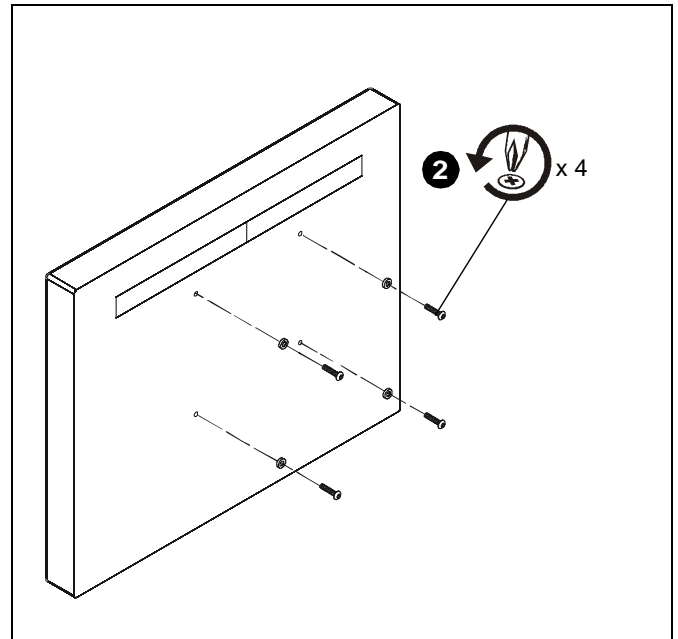
**Figure 5**

**Installing Interface Brackets to Display**

1. Place display face down on a soft, non-abrasive surface.
2. Remove four sets of bolts and washers that were shipped attached to the back of the display. Set hardware aside for re-use. (See Figure 6)

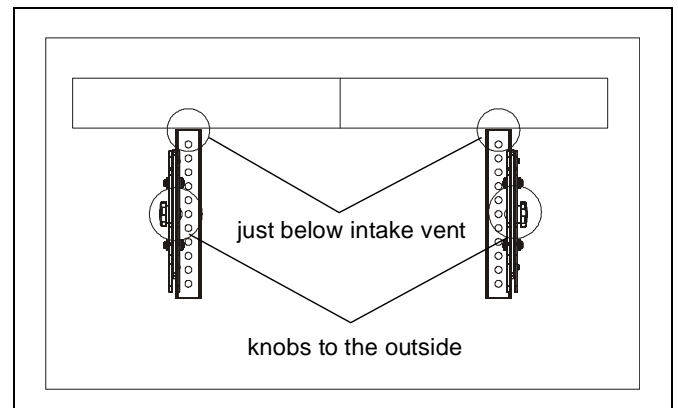


**WARNING:** The bolts and washers are designed to be permanent fixtures on the television. Never remove the bolts or washers except for installation of the wall mount! Always replace bolts immediately. Installing the television without the bolts and washers may result in serious personal injury and/or damage the television!



**Figure 6**

3. Place left and right interface brackets (B and C) on the back of the display, with the tension knob on each bracket facing toward the outside of the television. Place top of interface brackets just below intake vent on back of display. (See Figure 7)



**Figure 7**

4. Use four removed screws and washers to secure interface brackets (B and C) to back of display. (See Figure 8)

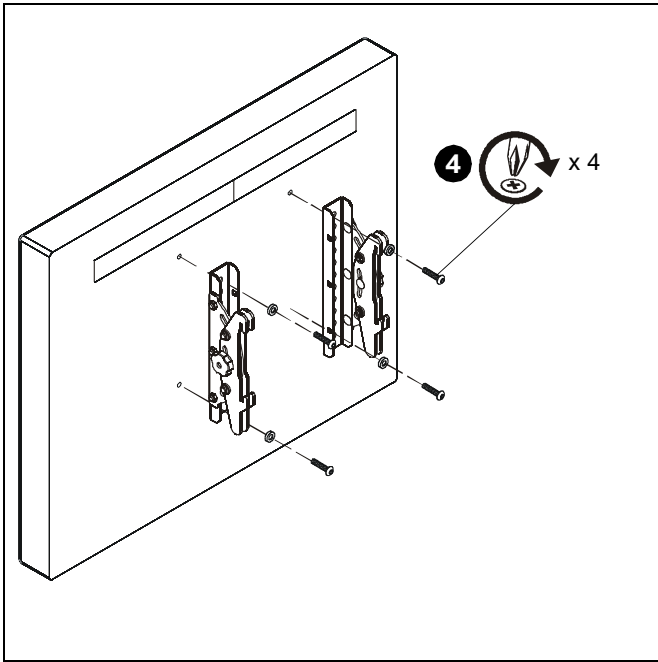


Figure 8

**Display Installation**



**WARNING:** Exceeding the weight capacity can result in serious personal injury or damage to equipment! It is the installer's responsibility to make sure the combined weight of all components located between the SB-WM46NA up to (and including) the display does not exceed 175 lbs (80 kg).

1. Place the display on the wall plate (A) by hooking the hooks of the brackets (B and C) in the top of the wall plate. (See Figure 9)
2. Secure the display by sliding the latches, one on each side, inward. As the latches are slid in, it will lower and catch the bottom hook and secure the television in place. (See Figure 9)
3. If desired, install self tapping screws (F) and/or padlocks (not provided) for additional security. (See Figure 9)
4. Tilt the display up or down as desired.
5. Loosen or tighten knobs to achieve the desired tension.

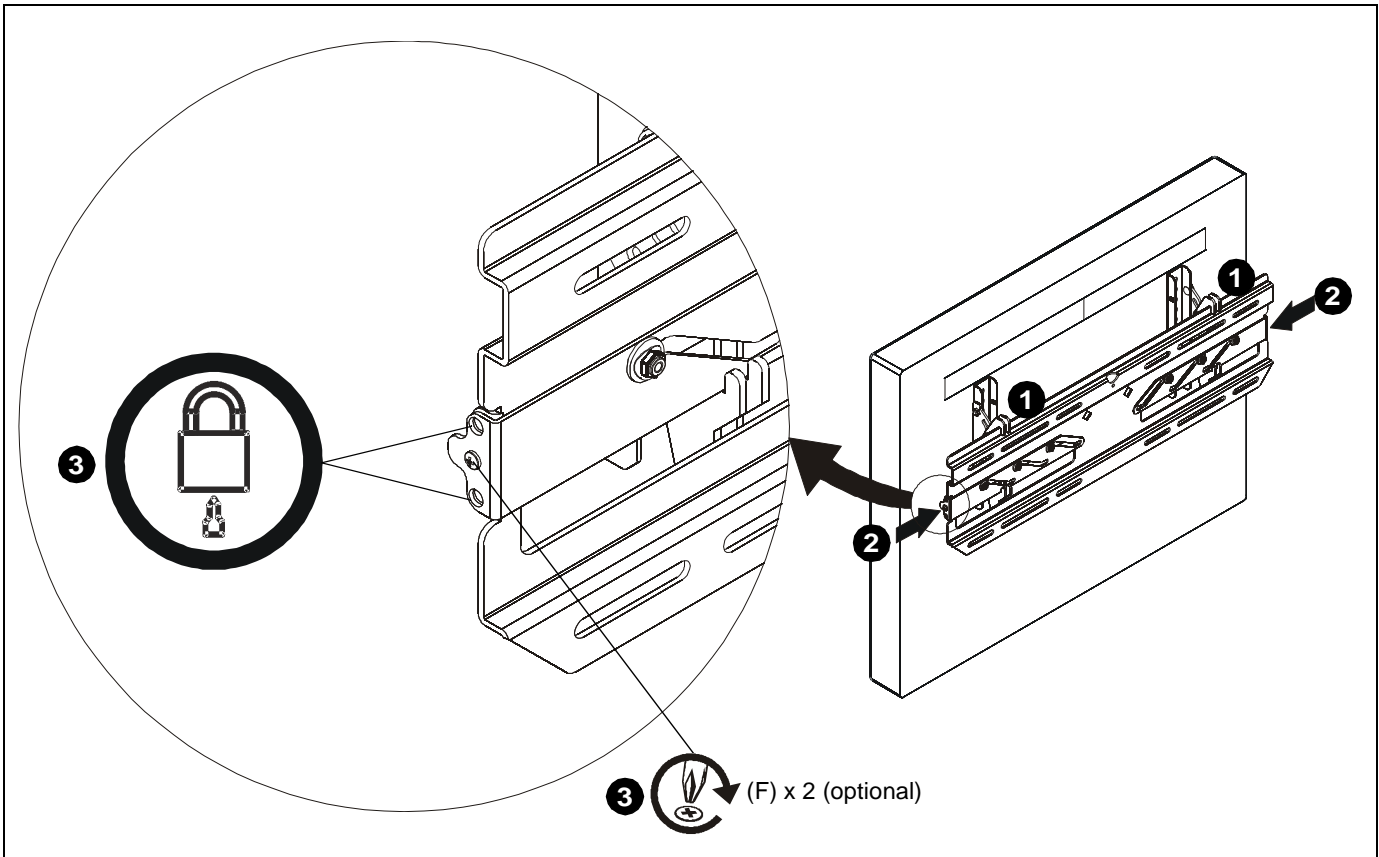


Figure 9



## Display Removal

To remove display:



**CAUTION:** Disconnect power and audio/video cables before removing the display from its wall mount.



**WARNING:** The display is heavy and extremely fragile. Exercise caution when removing the display from the mount to avoid equipment damage or personal injury.

1. If applicable, remove the self tapping screws (F) and/or padlocks from both sides of the wall plate. This hardware provides security. (See Figure 10)
2. Slide the security latches out on both sides to disengage the display from the wall plate. (See Figure 10)
3. With an assistant, lift the display up and off the wall plate to remove the display from the wall. (See Figure 10)

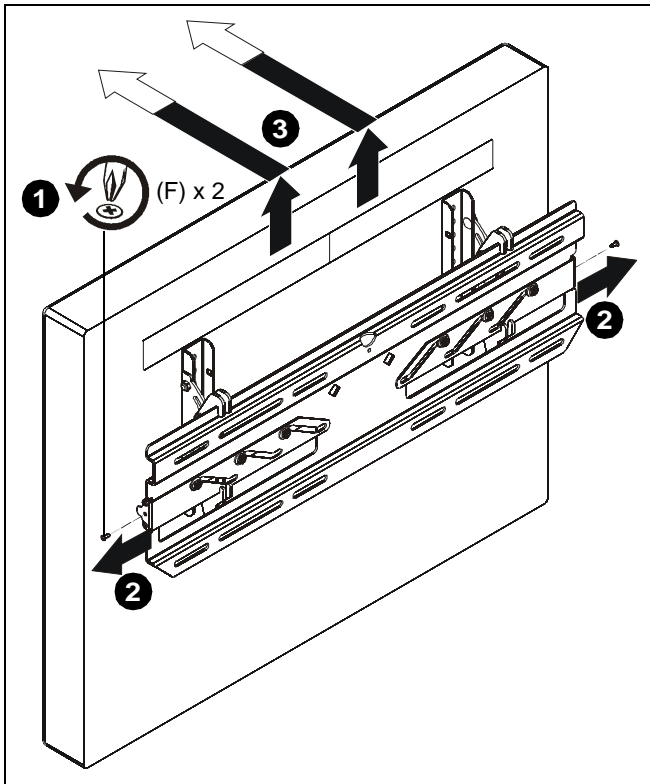


Figure 10





***SunBriteTV***<sup>®</sup>

8800-002155 Rev00  
04/12

**SunBriteTV, LLC**

2001 Anchor Court  
Thousand Oaks, CA 91320

866-357-8688

[www.sunbritev.com](http://www.sunbritev.com)

