

How to Retrofit a Wall-Mounted Wireless Keypad into an Existing Home

							
seeTouch Keypad	seeTouch Hybrid Keypad	Sunnata Keypad	Sunnata Hybrid Keypad	Pico Remote Control	Wallplate Bracket	Wall-Mounting Bracket	
RRD-W* HQRD-W*	RRD-HN* HQRD-HN*	RRST-W* HRST-W*	RRST-HN* HRST-HN*	PJ2-*	PICO-WBX-ADAPT	PJ2-WALL-WH-L01	

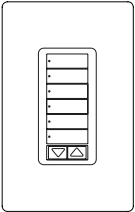
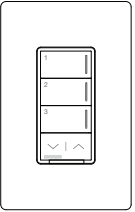
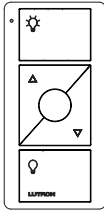
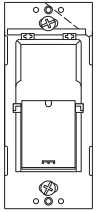

* Model number prefixes only – see product catalogs for complete list of model numbers

Table of Contents

Adding a Keypad to a Blank Wall	2
Adding a Keypad to the Side of an Existing Group of Dimmers/Switches	3
Replacing a Light Switch with a Keypad in a Single-Pole Circuit	4
Replacing Light Switches with a Keypad in a 3-Way/4-Way Circuit.....	5

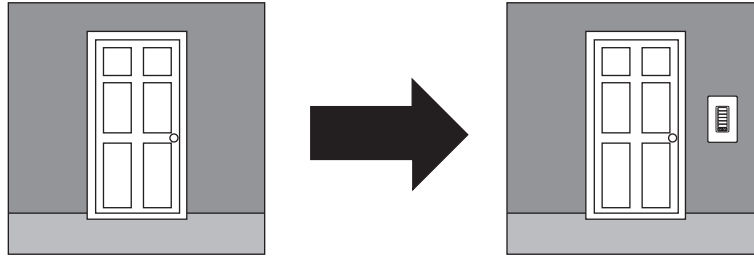
Adding a Keypad to a Blank Wall

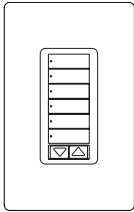
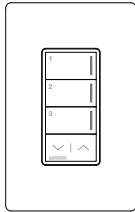
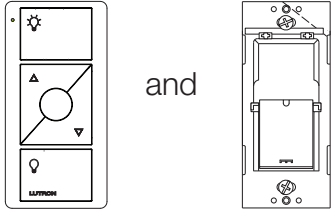
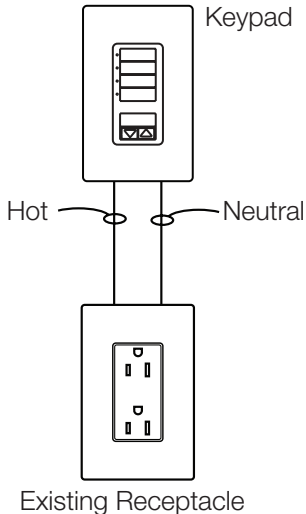

	If you can run electricity (120 V~) to this location:	If you <u>CANNOT</u> run electricity to this location:
	seeTouch Keypad 	Sunnata Keypad 
		Pico Remote Control and Wall-Mounting Bracket 
Caséta Wireless		PJ2-WALL-WH-L01
RadioRA 2	RRD-W	
RadioRA 3	RRD-W RRST-W	
HomeWorks	HQRD-W HRST-W	
Wallplate	CW-1 or SC-1	
Installation	Run 120 V~ from a nearby receptacle or electrical box to the new location. 	Mount the wall-mounting bracket per the included instructions and attach the Pico remote control. 

Adding a Keypad to the Side of an Existing Group of Dimmers/Switches

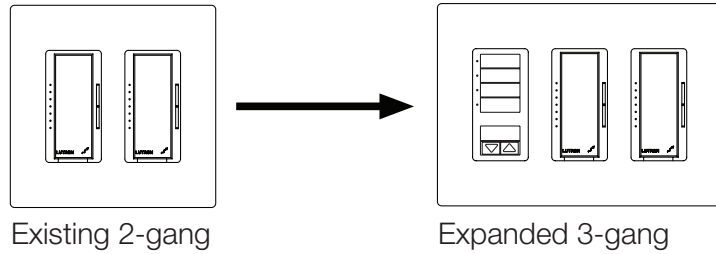

If you can extend/replace the electrical box behind the wall, and the electrical box has access to both the 120 V~ hot and neutral connections:	If you <u>CANNOT</u> extend/replace the electrical box behind the wall:
---	---

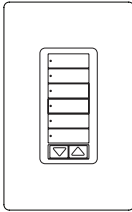
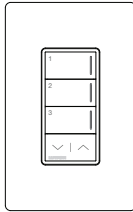
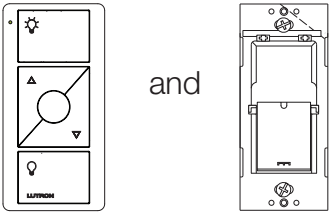
seeTouch Keypad 	Sunnata Keypad 	Pico Remote Control and Wallplate Bracket 
--	---	--

Caséta Wireless		
RadioRA 2	RRD-W	PJ2-*
RadioRA 3	RRD-W	and
HomeWorks	HQRD-W	PICO-WBX-ADAPT
Larger Wallplate	2-Gang: CW-2/SC-2	3-Gang: CW-3/SC-3 4-Gang: CW-4/SC-4

Installation

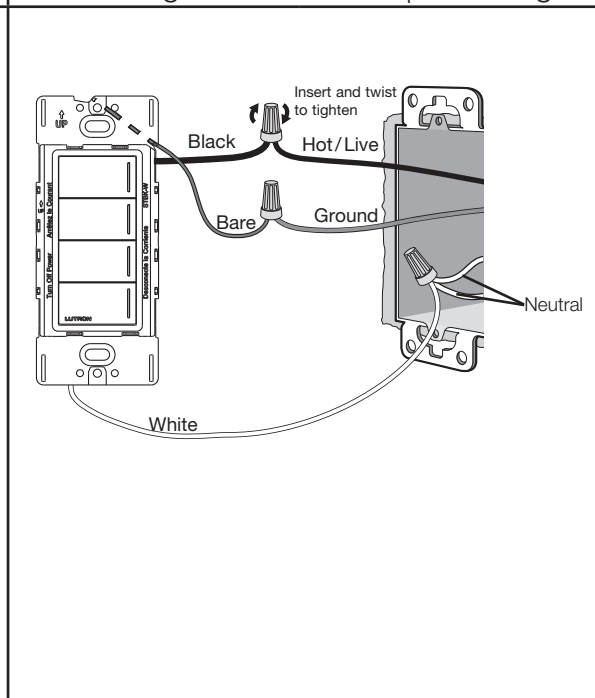

Before installing the new wallplate, attach the wallplate bracket to the new location of the wallplate.

Attach the wallplate to the group of existing dimmers/switches and attach the Pico remote control to the wallplate bracket.

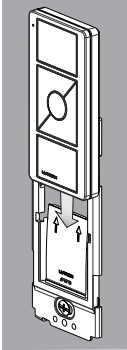

Replacing a Light Switch with a Keypad in a Single-Pole Circuit

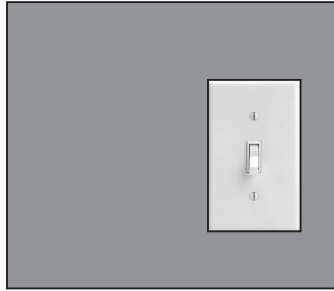

Single-Pole Light Switch

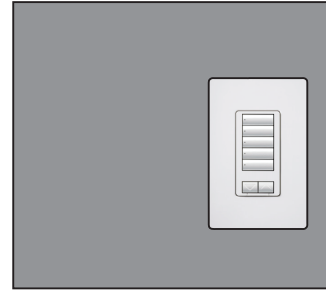

Replaced by a Keypad

If the electrical box has access to both the hot and neutral connections (120 V~):	If a neutral connection is <u>NOT</u> available where you want the keypad:
--	--

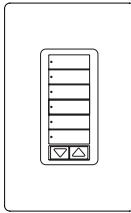
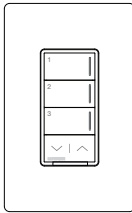
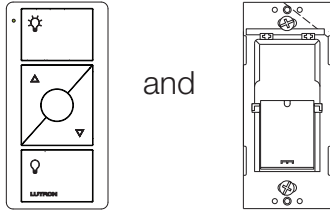
seeTouch Hybrid Keypad 	Sunnata Hybrid Keypad 	Pico Remote Control and Wallplate Bracket 
---	--	--

Caséta Wireless			
RadioRA 2	RRD-HN		PJ2- [*] and PICO-WBX-ADAPT
RadioRA 3	RRD-HN	RRST-HN	
HomeWorks	HQRD-HN	HRST-HN	
Wallplate	CW-1- [*] or SC-1- [*]		CW-1- [*] or SC-1- [*]

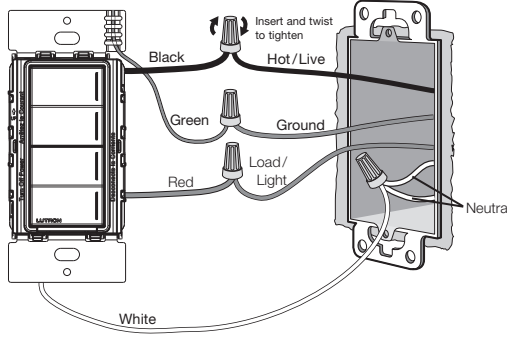
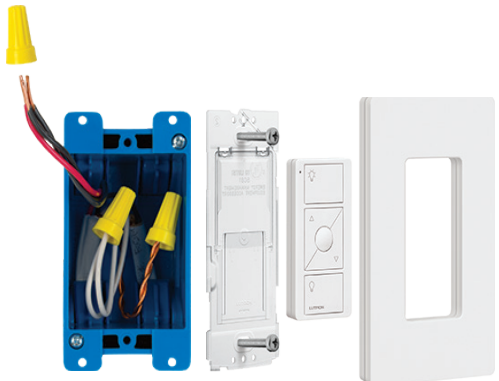
Installation See product installation instructions for full details.	Replace the light switch with the hybrid keypad. Connect the hybrid keypad's white wire to the neutral wire. 	Remove the light switch, connect the hot and switched-hot wires together with a wire nut, install the wallplate bracket, attach the Pico remote control and the wallplate. 
---	--	---

Replacing Light Switches with a Keypad in a 3-Way/4-Way Circuit

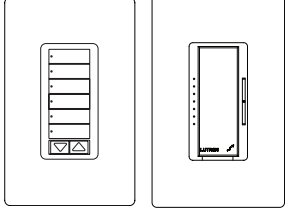
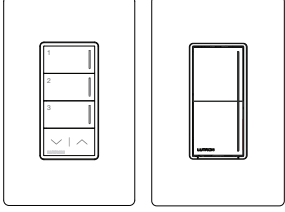
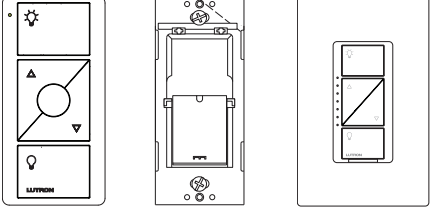
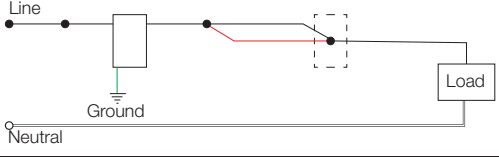
	If 120 V~ hot and neutral connections are available where you want the keypad:		If hot and neutral connections are <u>NOT</u> available where you want the keypad:
	see Touch Keypad and Dimmer 	Sunnata Keypad and Dimmer 	Pico Remote Control, Wallplate Bracket, and Dimmer 
Caséta Wireless			Pico: PJ2 Adapter: PICO-WBX-ADAPT Dimmer: PD-6WCL
RadioRA 2	Keypad: RRD-W Dimmer: RRD-PRO		Pico: PJ2 Adapter: PICO-WBX-ADAPT Dimmer: RRD-PRO
RadioRA 3	Keypad: RRD-W Dimmer: RRD-PRO	Keypad: RRST-W Dimmer: RRST-PRO-N	Pico: PJ2 Adapter: PICO-WBX-ADAPT Dimmer: RRST-PRO-N or RRD-PRO
HomeWorks	Keypad: HQRD-W Dimmer: HQRD-PRO	Keypad: HRST-W Dimmer: HRST-PRO-N	Pico: PJ2 Adapter: PICO-WBX-ADAPT Dimmer: HRST-PRO-N or HQRD-PRO
Installation	See next page.		

Replacing Light Switches with a Keypad in a 3-Way/4-Way Circuit (continued)

	Incoming 120 V~ power and outgoing lighting load connections are in the same 3-way location:	Incoming 120 V~ power is at one 3-way location and the outgoing lighting load connection is at the other 3-way location:
Example of the Existing Wiring:		
Option A:		
Option B:		

The examples shown here are for educational purposes only. Actual wire colors and connection methods may differ from what is shown here. Consult the product's installation instructions for full details.

NOTE: If the incoming 120 V~ power is run directly to the fixture, a wired keypad will NOT work and you must use the Pico remote control option.

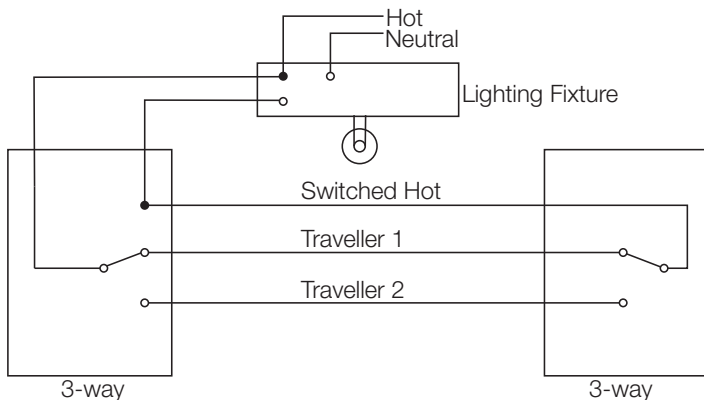

Lutron, Claro, Pico, seeTouch, Caséta, HomeWorks, RadioRA, RadioRA 2, RadioRA 3, and Sunnata are trademarks or registered trademarks of Lutron Electronics Co., Inc. in the US and/or other countries.

Lutron Contact Numbers

WORLD HEADQUARTERS

USA
Lutron Electronics Co., Inc.
7200 Suter Road
Coopersburg, PA 18036-1299
TEL: +1.610.282.3800
FAX: +1.610.282.1243
support@lutron.com
www.lutron.com/support

North & South America
Customer Assistance
USA, Canada, Caribbean:
1.844.LUTRON1 (1.844.588.7661)
Mexico:
+1.888.235.2910
Central/South America:
+1.610.282.6701

UK AND EUROPE:

Lutron EA Limited
125 Finsbury Pavement
4th floor, London EC2A 1NQ
United Kingdom
TEL: +44.(0)20.7702.0657
FAX: +44.(0)20.7480.6899
FREEPHONE (UK): 0800.282.107
Technical Support: +44.(0)20.7680.4481
lutronlondon@lutron.com

ASIA:

Lutron GL Ltd.
390 Havelock Road
#07-04 King's Centre
Singapore 169662
TEL: +65.6220.4666
FAX: +65.6220.4333
Technical Support: 800.120.4491
lutronsea@lutron.com

Asia Technical Hotlines

Northern China: 10.800.712.1536
Southern China: 10.800.120.1536
Hong Kong: 800.901.849
Indonesia: 001.803.011.3994
Japan: +81.3.5575.8411
Macau: 0800.401
Taiwan: 00.801.137.737
Thailand: 001.800.120.665853
Other Countries: +65.6220.4666