

# MM720 Standard Pull Down TV Mount

- ▶ **Read this entire manual before you begin.**
- ▶ **Do not unpack box contents until verifying the requirements listed on page 4.**

## ⚠ **WARNING!**

This product contains small parts that can be a choking hazard. Do not let children play with any of these small parts! Keep children away from the work area during installation.

## ⚠ **Caution**

This product is intended to be installed by professional installation contractors, or persons familiar with the tools and methods required for this installation. If you are not sure about your ability to perform this installation, you must contact a professional. MantelMount is not responsible for damage or injury caused by incorrect installation or improper use.

## ⚠ **Caution**

Do not let children operate, pull on, or hang from MantelMount. Do not let children push MantelMount upward to the top position - this will cause the mount to slam against the wall due to the upward force of the springs. Only a person tall enough to control the mount all the way to the top should operate MantelMount.

## ⚠ **Caution**

Do not use this product in any way, or for any purpose, that is not specifically described in these instructions. MantelMount is not responsible for damage or injury caused by incorrect installation or improper use.

## INSTALLATION INSTRUCTIONS

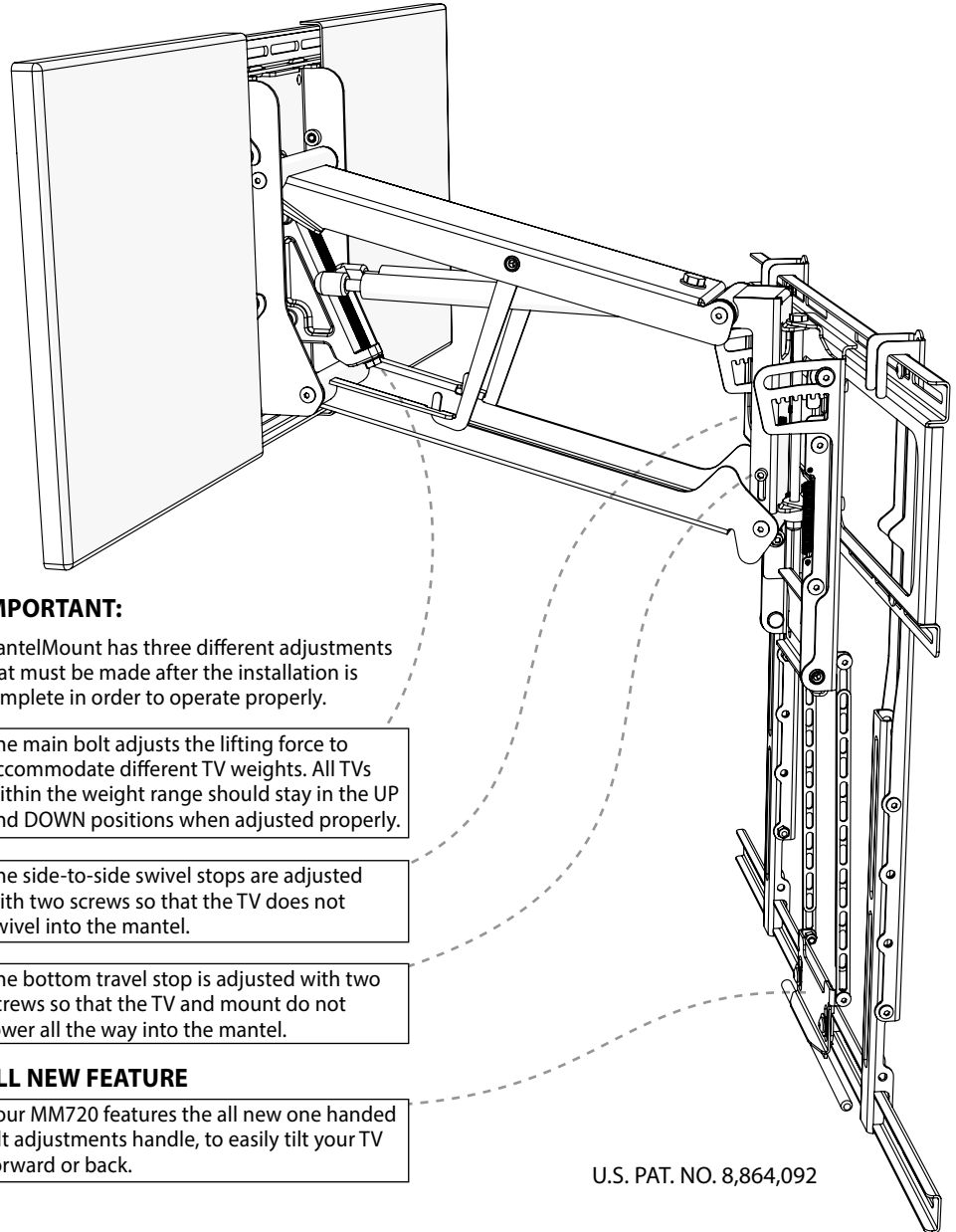

### **IMPORTANT:**

MantelMount has three different adjustments that must be made after the installation is complete in order to operate properly.

The main bolt adjusts the lifting force to accommodate different TV weights. All TVs within the weight range should stay in the UP and DOWN positions when adjusted properly.

The side-to-side swivel stops are adjusted with two screws so that the TV does not swivel into the mantel.

The bottom travel stop is adjusted with two screws so that the TV and mount do not lower all the way into the mantel.

### **ALL NEW FEATURE**

Your MM720 features the all new one handed tilt adjustments handle, to easily tilt your TV forward or back.

U.S. PAT. NO. 8,864,092

**If you need help, call 1.800.897.9755 ext.1**

For missing/damaged parts or questions during installation, contact our Customer Support team at **1.800.897.9755 ext.1** or **support@mantelmount.com**.

Customer satisfaction is our highest priority!

Watch an installation video or access a PDF of this manual at **MantelMount.com/FAQs/Specs and Manuals**.

**Contains important safety information – please save! MantelMount.com**



# BEFORE INSTALLATION

## 1 Verify TV and mount space meet these criteria:

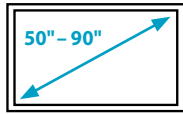

**SCREEN SIZE**  
50" to 90"  
(Diagonally)



**WEIGHT CAPACITY**  
25 to 115 LBS.  
(Including Sound Bar)

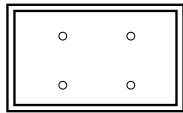

**VESA COMPLIANT**  
Up to 600mm X 600mm

**MANTEL DEPTH**  
18" MAXIMUM

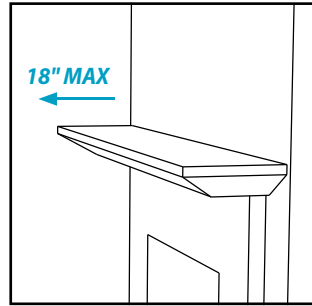

**WOOD STUDS FOR MOUNTING**

Studs Maximum 28" apart;  
Wall Covering Maximum 5/8"

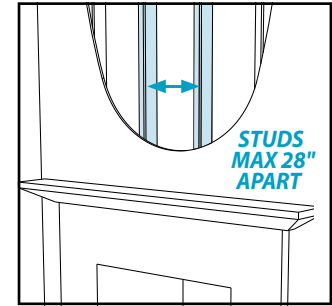

## 2 Verify MantelMount will fit the wall space.

**A.** Use the reference diagram (right) and chart (below) to write down the following measurements (in inches):

**Wall Space Height:** \_\_\_\_\_ (Distance from mantel to ceiling/crown molding.)

**TV Height:** \_\_\_\_\_ (Include sound bar height if placing below TV.)

**Mantel Depth:** \_\_\_\_\_ (Distance mantel extends away from the wall.)

**Required Vertical Space:** \_\_\_\_\_ (Calculation from chart below.)

**B.** If the Required Vertical Space is less than or equal to the Wall Space Height, then MantelMount will fit the wall space.

If Mantel Depth is:	Required Vertical Space is:
Less than 8"	TV height + 2"
9" – 11"	TV height + 4"
11" – 14"	TV height + 6"
14" – 18"	TV height + 9"

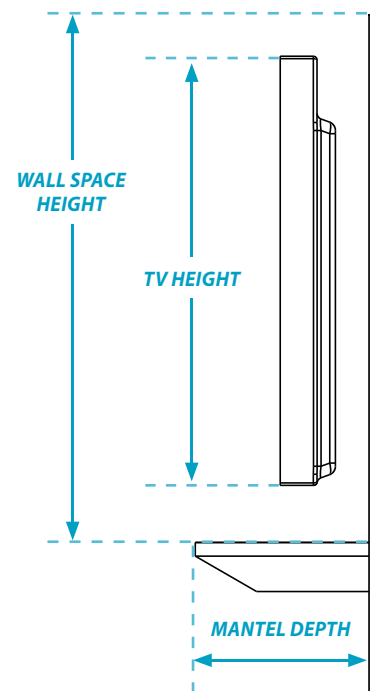

## 3 Verify you have the required tools.

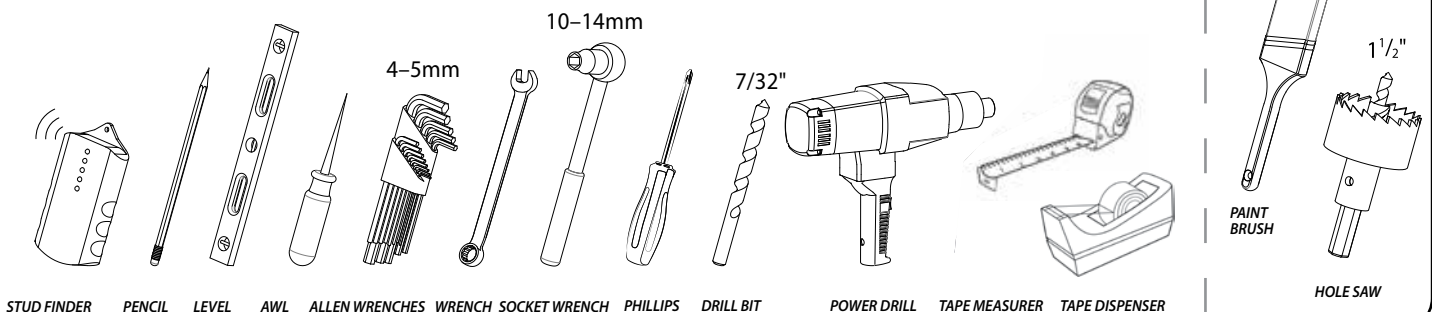

# BEFORE INSTALLATION

## 4 Verify all parts are included.

### SILVER SCREWS FOR BACK OF TV

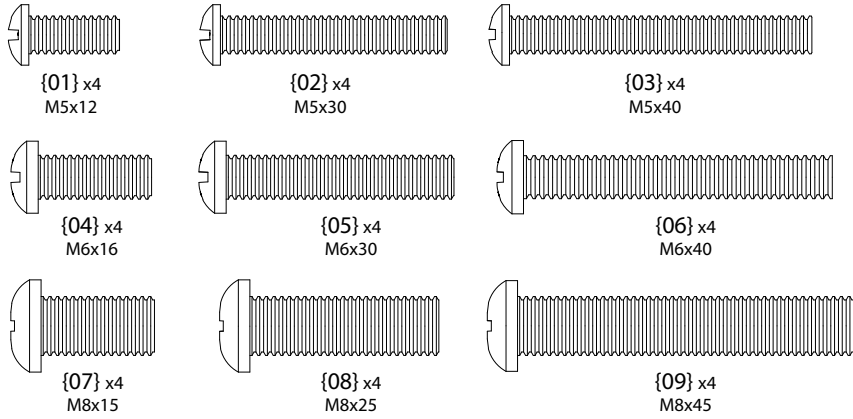

### BLACK PARTS FOR MOUNT

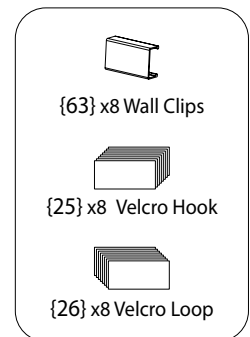
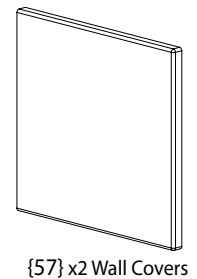
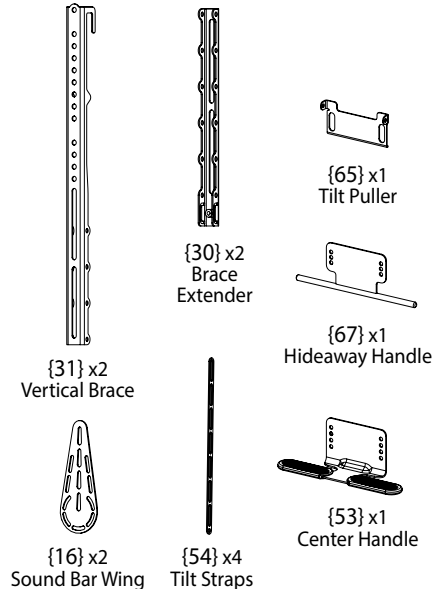
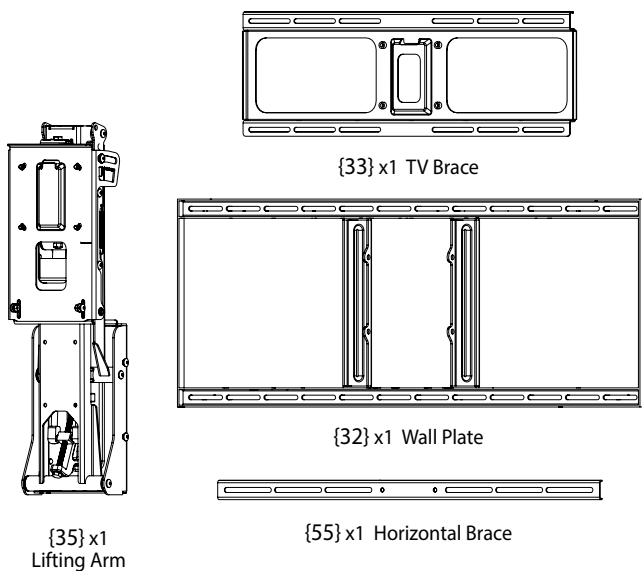
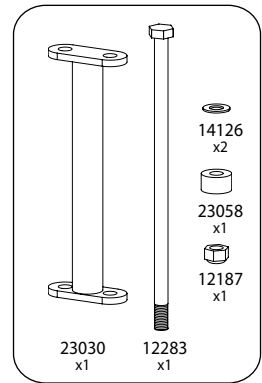
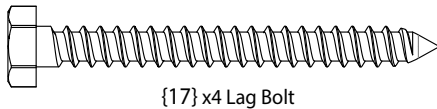
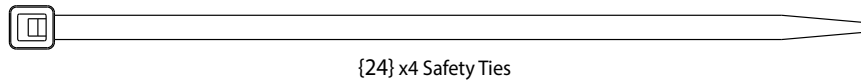
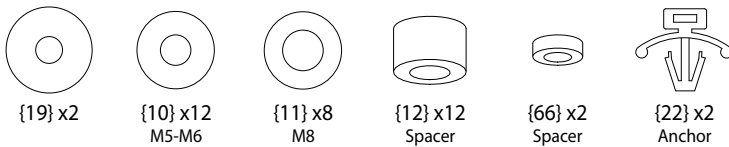
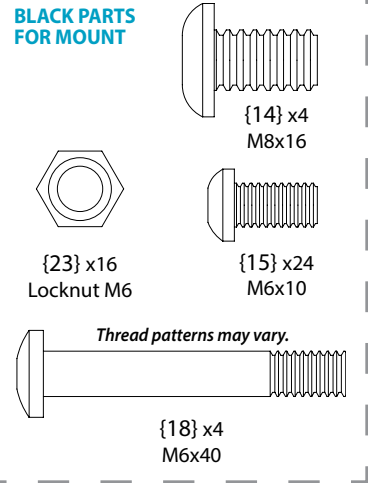

If any parts are missing or damaged, contact Customer Support at 1-800-897-9755 x1 before installing.

# MM720 INSTALLATION STEPS

<b>STEP 1 Attach Braces to TV</b> .....	PAGE 5
<b>STEP 2 Determine Wall Placement</b> .....	PAGE 8
<b>STEP 3 Attach Mount to Wall</b> .....	PAGE 11
<b>STEP 4 Attach TV to Mount</b> .....	PAGE 15
<b>STEP 5 Make Final Adjustments</b> .....	PAGE 18

## **⚠ WARNING**

**Keep children away from the work area during installation.**

This product contains small parts, please keep out of reach from children.

## **⚠ WARNING**

**Do not remove the gas springs or any bolts that hold the Lifting Arm together.**

## **⚠ WARNING**

**Do not let small children pull on or hang from MantelMount.**

Only persons tall enough to control the product all the way to the top/raised position should operate MantelMount.

Do not allow small children to push MantelMount upward to the top position. This will cause the mount to slam against the wall due to the upward force of the springs.

## **⚠ CAUTION**

**This product is intended to be installed by professional contractors or persons familiar with the tools and methods required for this installation.**

If you are uncertain about your ability to perform this installation, please contact a professional.

**Do not use this product in any way or for any purpose that is not specifically described in these instructions.**

## **⚠ CAUTION**

**Do not use this product for purposes not specifically described in these instructions.**

MantelMount is not responsible for damage or injury caused by incorrect installation or improper use.

MantelMount is not responsible for damage or injury caused by incorrect installation or improper use.

## Symbols Used in this Manual



CAUTION / WARNING



HELPFUL INFORMATION



DO NOT



SPECIAL NOTE



REQUIRES TWO PEOPLE

- ▶ **Two people required for parts of this installation.**
- ▶ **Installation Tips & Videos:** <http://mantelmount.com/install-tips>
- ▶ **Questions during installation?** Contact Customer Support:  
Monday – Friday, 7am – 4pm PST 1.800.897.9755 x1 or [support@mantelmount.com](mailto:support@mantelmount.com)

U.S. Pat. No. 8,864,092

For more information on MantelMount patented technology visit: [www.mantelmount.com/pages/patents](http://www.mantelmount.com/pages/patents)





# STEP 1

## Attach Braces to TV\*

In order for the TV to hide the Mount on the wall, the Braces must be at least 4" higher than the bottom of TV (or Soundbar if one is installed).

If you are using an RB100 Recess Box then they must be more than 6" higher to hide the Recess Box.

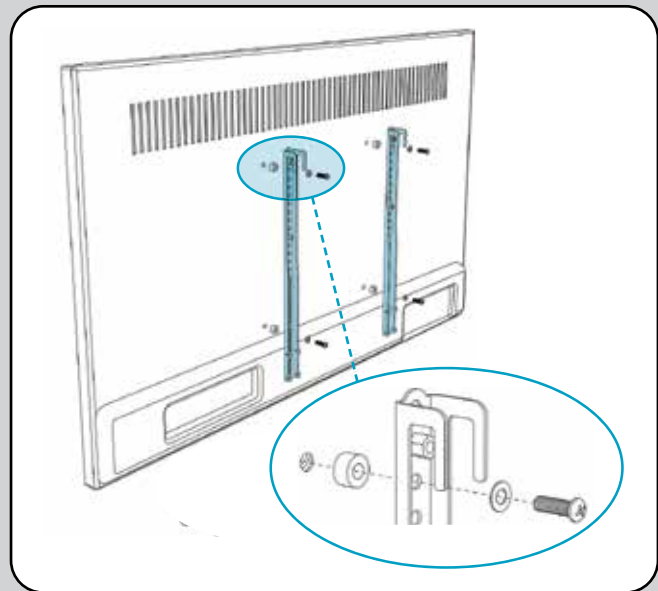

### 1.1 Test-fit Brace components on back of TV.

Place TV screen-side down on a flat, blanketed surface. Lay out components to check assembly configuration. If installing a sound bar, refer to STEP 1.8.

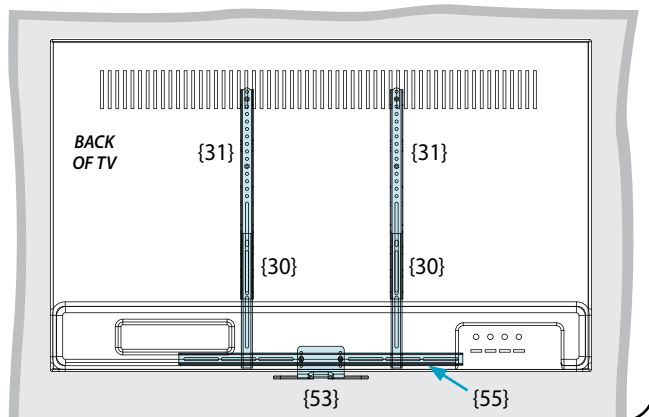

### 1.2 Determine if TV has a flat or irregular back.

An irregular back will require Spacers {12} and longer Screws to fill spaces between the Vertical Brace {31} and the TV. The Braces must be parallel to television screen.

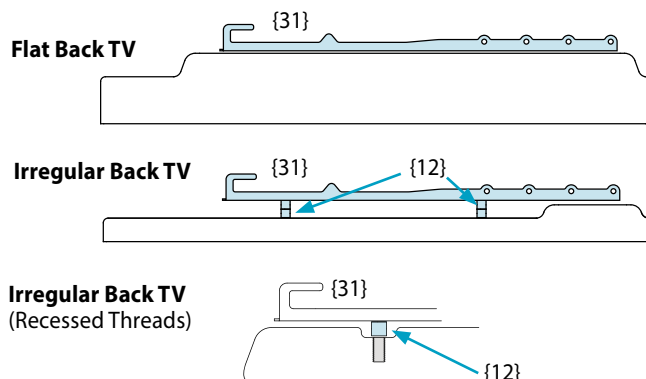

### 1.3 Select Screws and Spacers.

If Spacers {12} are required, choose one of these Screw combinations shown with maximum Spacer usage.

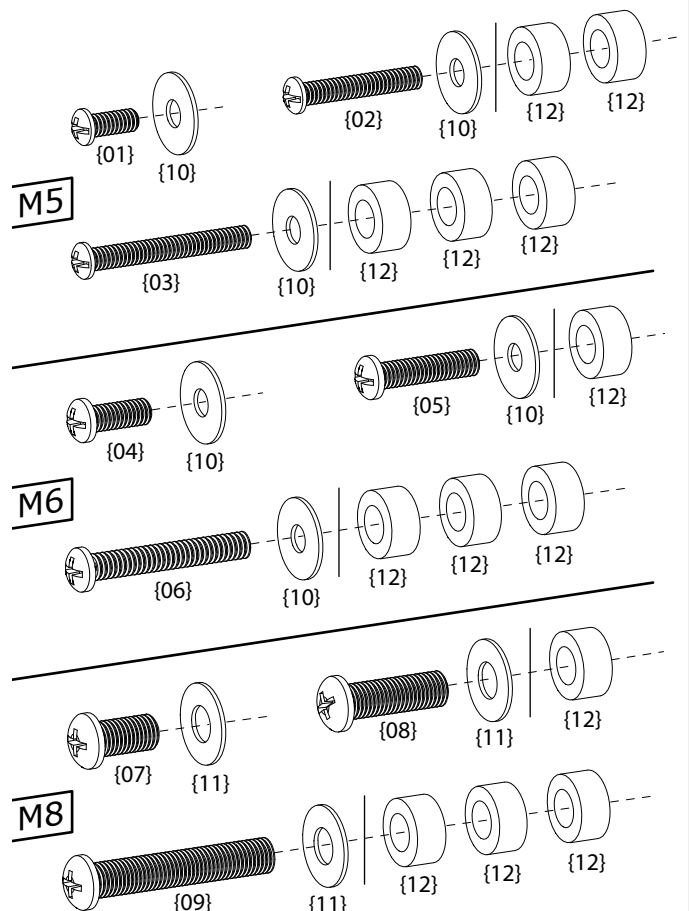

## 1.4 Hand-thread screw combination into the TV.

Ensure there is adequate thread engagement without hitting the bottom of threaded insert.

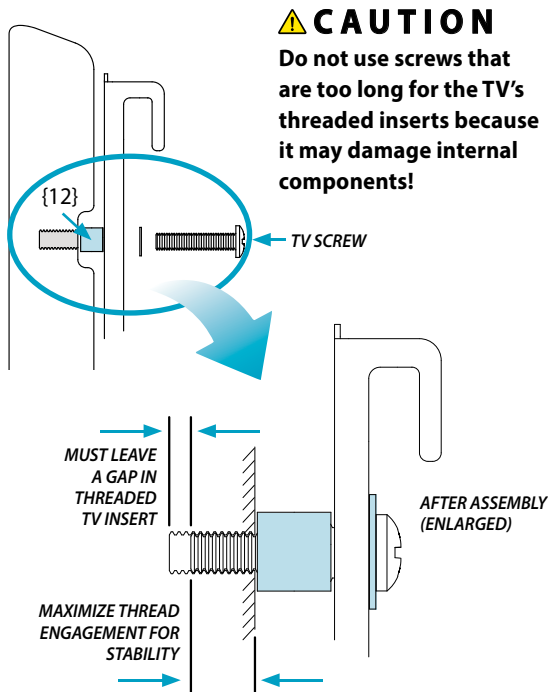

**CAUTION**  
Do not use screws that are too long for the TV's threaded inserts because it may damage internal components!

## 1.5 Attach the Vertical Braces to the back of TV.

Install the Vertical Braces {31} so that the bottoms of the braces are between 4" to 10" from the bottom of TV, (\*or Soundbar if one is installed) centering the braces vertically as much as possible.

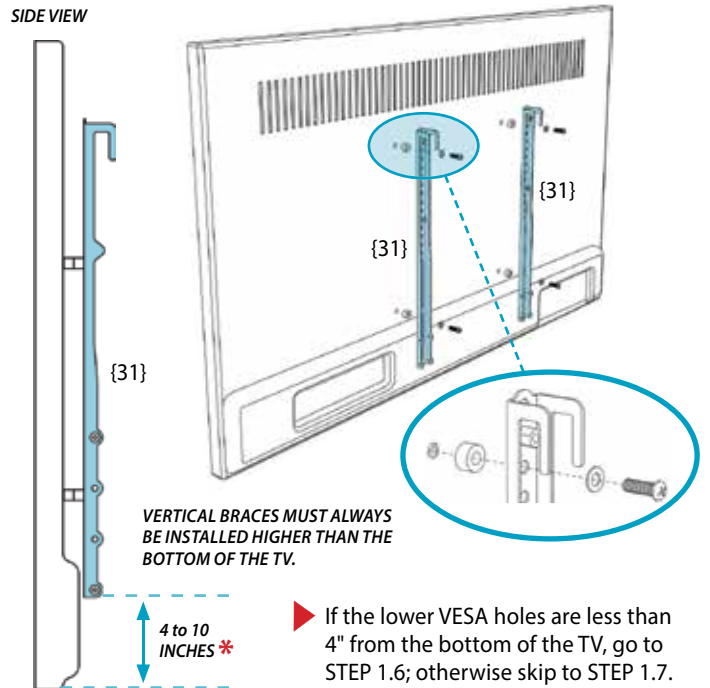

▶ If the lower VESA holes are less than 4" from the bottom of the TV, go to STEP 1.6; otherwise skip to STEP 1.7.

*\*If installing this mount with a MantelMount RB100 Recess Box, the bottom of the Vertical Brace must be more than 6" and up to 10" from the bottom of TV (or more than 6" from the bottom of the Soundbar if one is installed).*

## 1.6 If the lower VESA holes are less than 4" from the bottom of the TV:

OPTIONAL

{31}

Connect the Vertical Braces {31} through the UPPER VESA holes only, so that the bottom of the braces are between 4" to 10" from the bottom of the TV. \*

If the only option is to attach the Vertical Braces to the **Upper** Vesa holes through a slot: 1) Hand-thread the screw through the slot; 2) slide the Vertical Brace upward until the screw meets the bottom of the slot; and 3) tighten the screw.

▶ You must attach the Brace Extenders {30} to the Vertical Braces as described in STEP 1.7. However, you must also attach the **LOWER** VESA hole through the Brace Extender as shown.

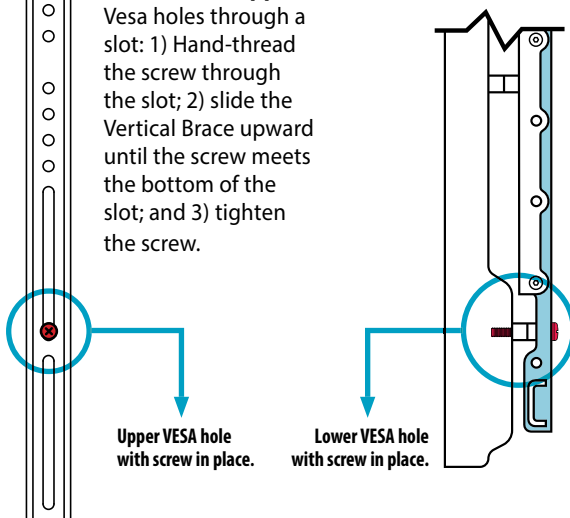

## 1.7

Rules for mounting the Extenders {30}

OPTIONAL

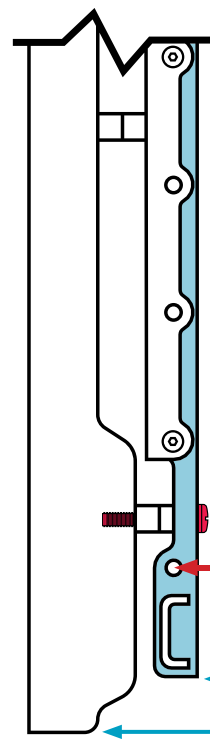

**A: DO NOT** use the lowest hole on the extender (30)

**B: If you are NOT using a Soundbar,** the Extenders {30} must be 1 inch above the bottom of the TV to leave room for the Handle.

**DO NOT** use this lowest hole.

## 1.8 Attach the Horizontal Brace to Brace Extenders.

Slide one Brace Extender {30} onto the left end of the Horizontal Brace {55}, then slide the other Brace Extender onto the opposite right end.

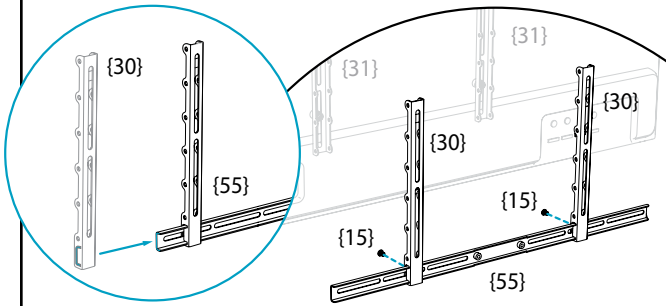

Align the Brace Extenders with the Vertical Braces (that are already mounted to the back of the TV) while positioning the Horizontal Brace so that it extends an equal amount on either side of the Brace Extenders. Attach Horizontal Brace to Brace Extenders w/Screws {15}.

## 1.9 Attach Brace Extenders to the Vertical Braces.

Slide the Brace Extenders {30} (with the Horizontal Brace {55} now attached to them) onto the Vertical Braces {31}. Position it so that the Horizontal Brace will be hidden by the TV. Use Screws {18} and Nuts {23} to attach.

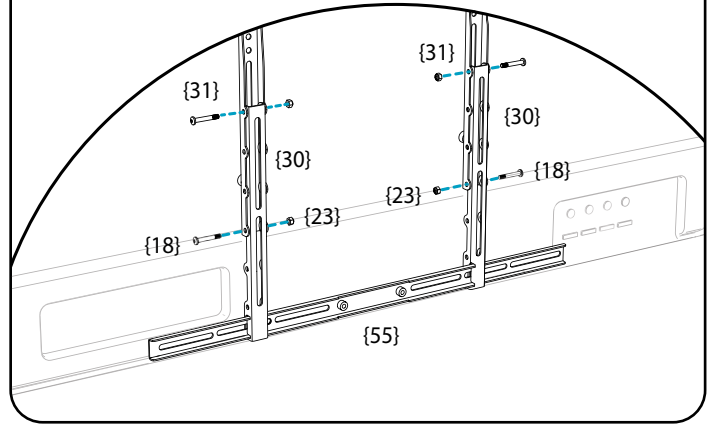

## 1.10 If installing a sound bar, attach the Sound Bar Wings.

OPTIONAL

Use Screws {15} and Nuts {23} to attach the Sound Bar Wings {16} to the Horizontal Brace {55}. Position the Wings to fit the mounting holes of the sound bar.

Install sound bar. See below for Sound Bar Wing installation information.

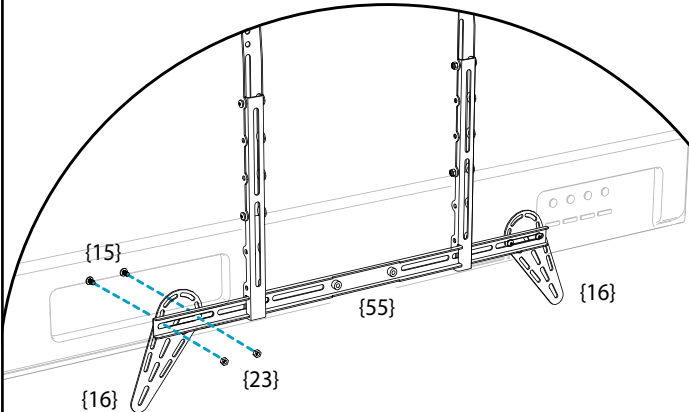

### Arrange Sound Bar Wings and sound bar to work with the Heat-Sensing Center Handle.

The Sound Bar Wings may be positioned and rotated so that the Center Handle {53} will reach below the sound bar.

For example, if a sound bar is tall, the Brace Extenders {30} and Horizontal Brace can be attached lower down on the Vertical Braces toward the bottom of the sound bar while the Wings point upwards in order to align with the sound bar's installation holes.

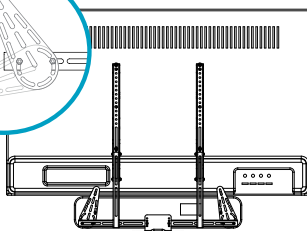
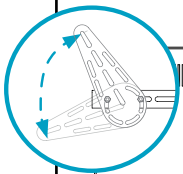

TALLER SOUND BAR

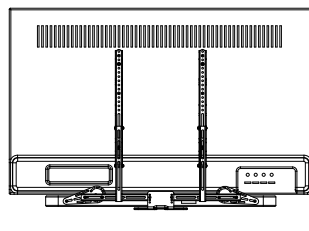

WIDER SOUND BAR

## Tilt Handle Configuration Options

The MM720 was designed with two tilt handle configuration options. Both options will allow you to tilt your television equally. Choose the handle configuration that works best for your mounting situation. **DO NOT install BOTH HANDLES.**

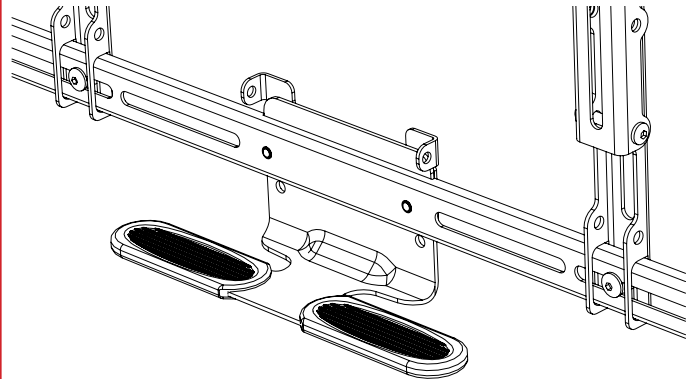

### Option A: Heat-Sensing Handle Configuration.

Our patented Heat-Sensing Handle turns red if the temperature above the fireplace exceeds a safe 110° F – a visual cue that either the TV needs to be raised to the UP position or the fireplace needs to be turned off.

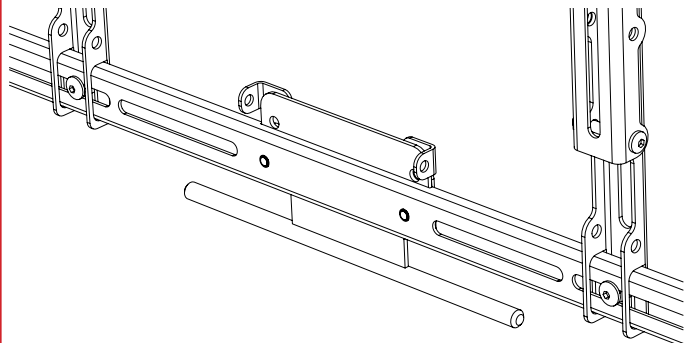

### Option B: Hideaway Handle configuration.

Allows for the handle to be hidden away behind the television while still giving access to the mounts tilt feature.

# 1.11 - Tilt Handle Configuration Options: Heat Sensing Handle: **OPTION A** Hideaway Handle : **OPTION B**

(Choose Your Handle Option)

**NOTE** The tilt function does not work with the Recess Box RB100, because the TV will be too close to the wall. If you intend to use the RB100 Recess Box on with your MantelMount installation **DO NOT** use parts {65} or {54}.

## 1.11A Option A: Heat Sensing Handle

Attach the Heat Sensing Handle {53} and the Tilt Puller {65} as shown, using Spacers {66}, Washers {19} and Screws {15}. The Spacers {66} **MUST BE** located inside the slots of the Tilt Puller. The Spacers will clamp tightly against the Heat Sensing Handle while still allowing the Tilt Puller to slide freely.

The Heat Sensing Handle should be within one inch **BELOW** the bottom of the TV or Soundbar so that it can be easily grabbed to move the TV."

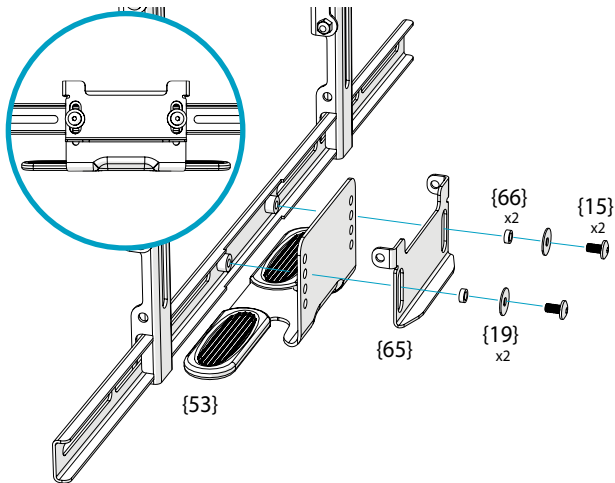

Attach two Tilt Straps {54} to the Tilt Puller {65} using two screws {15} and two nuts {23}. When attaching the straps together be sure the screws and nuts are attached to the end of the straps.

**IMPORTANT NOTE:** The Screws {15} must be on the **OUTSIDE**, and the Nuts {23} must be on the **INSIDE**.

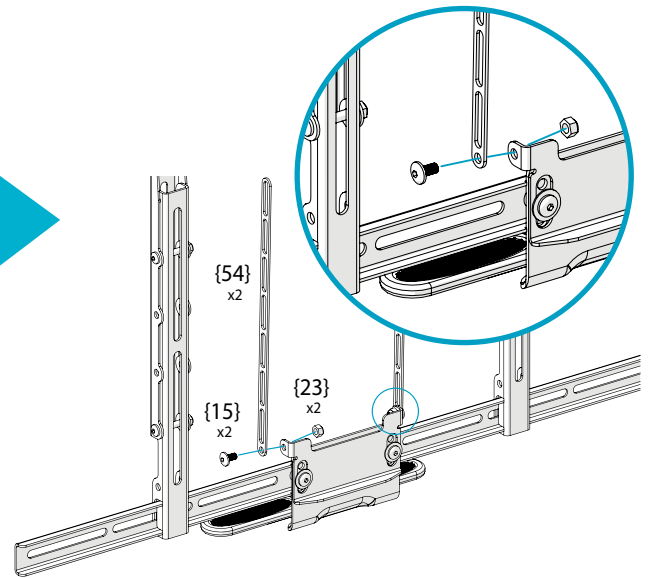

## 1.11B Option B: Hideaway Handle

Attach the Hideaway Handle {67} and the Tilt Puller {65} as shown, using Spacers {66}, Washers {19} and Screws {15}. The Spacers {66} **MUST BE** located inside the slots of the Tilt Puller. The Spacers will clamp tightly against the Hideaway Handle while still allowing the Tilt Puller to slide freely.

The Hideaway Handle should be within one inch **ABOVE** the bottom of the TV or Soundbar so that it can be easily grabbed to move the TV."

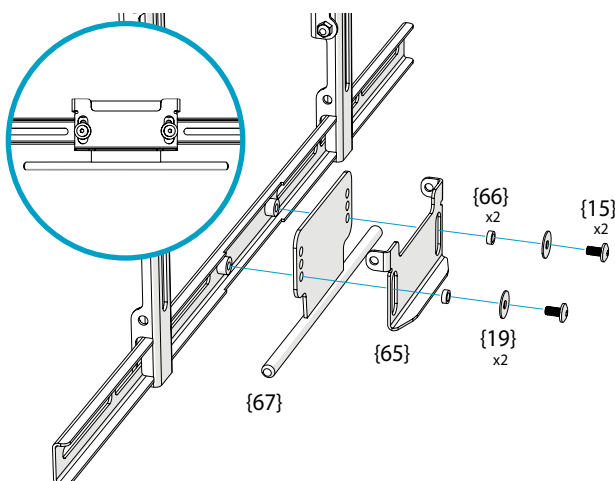

Attach two Tilt Straps {54} to the Tilt Puller {65} using two screws {15} and two nuts {23}. When attaching the straps together be sure the screws and nuts are attached to the end of the straps.

**IMPORTANT NOTE:** The Screws {15} must be on the **OUTSIDE**, and the Nuts {23} must be on the **INSIDE**.

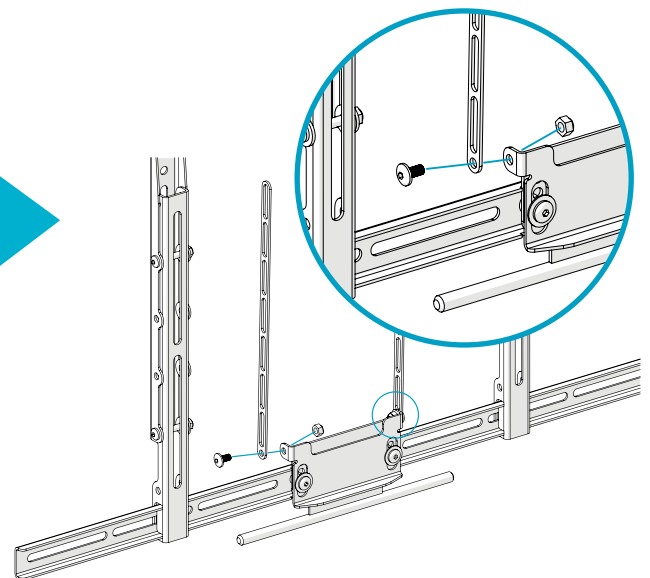

# STEP 2

## Determine Wall Placement

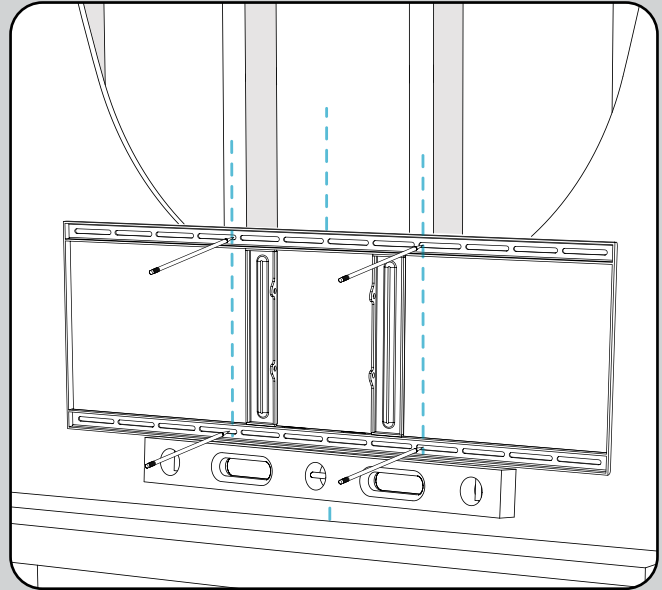

**2.1** Measure the distance from the bottom of the Vertical Braces {31} (not the Extenders) to the bottom of the TV/ sound bar.\*

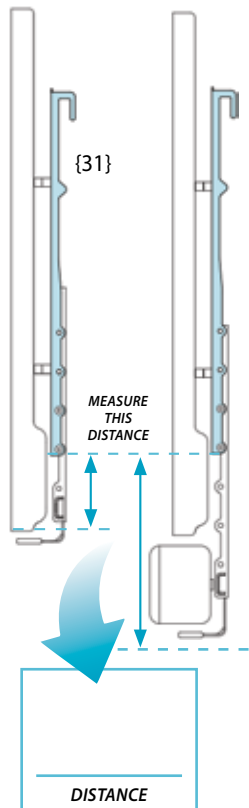

\*If installing this mount with a MantelMount RB100 Recess Box, the bottom of the Vertical Brace must be more than 6" from the bottom of TV (or 6" from the bottom of the Soundbar if one is installed).

**2.2** Determine the minimum vertical position of the Wall Plate.

Use the Look-up Table below to find the minimum distance between the mantel and the bottom of the lower Wall Plate {32}. This will be the intersection of the distance from STEP 2.1 and the mantel depth. Write the minimum distance in the box below.

DEPTH OF MANTEL →

	8" OR LESS	9"	10"	11"	12"	13"	14"	15"	16"	17"	18"
4"	4	4.5	5	5.5	6	6.5	7.25	8	9.25	10.8	13
5"	5	5.5	6	6.5	7	7.5	8.25	9	10.3	11.8	14
6"	6	6.5	7	7.5	8	8.5	9.25	10	11.3	12.8	15
7"	7	7.5	8	8.5	9	9.5	11.3	11	12.3	13.8	16
8"	8	8.5	9	9.5	10	10.5	11.3	12	13.3	14.8	17
9"	9	9.5	10	10.5	11	11.5	12.3	13	14.3	15.8	18
10"	10	10.5	11	11.5	12	12.5	12.3	14	15.3	16.8	19

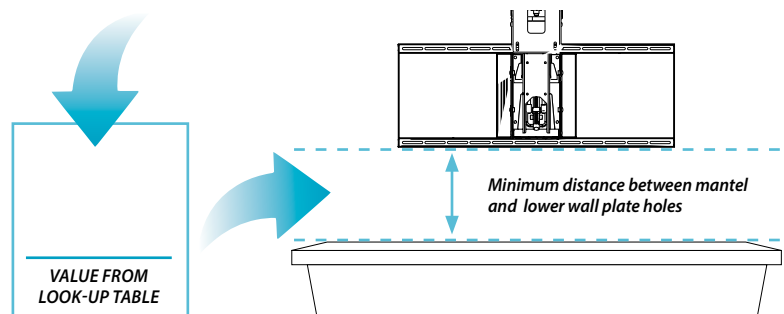

► Most customers want their TV mounted as close to the mantel as possible. If this describes you, go directly to STEP 2.4.

However, if you want the TV higher on the wall (such as centered between the mantel and ceiling) e.g. for extra space on the mantel for pictures or a center speaker, continue to STEP 2.3.

## 2.3

### Determine a higher vertical position of the Wall Plate.

OPTIONAL

Some customers want the TV centered between the mantel and the ceiling or crown molding. Others want enough space below the TV for pictures or a center speaker.

The TV's position on the wall is directly related to the placement of the lower Wall Plate. To determine exactly where to place the lower Wall Plate, choose an option below that best describes your scenario and fill in the boxes.

► **NOTE: Distance "E" below must always be at least the minimum distance in STEP 2.2**

#### Option 1: I want the TV centered between the mantel and ceiling/crown molding.

1. Record measurements already taken:

Wall Space Height (from pg. 2)

TV Height (from pg. 2)

Distance from STEP 2.1 (from pg. 8)

2. Subtract the TV Height (B) from the Wall Space Height (A), then divide by 2.

$$\frac{(A) - (B)}{2} = \text{[ (D) ]}$$

3. Add (C) and (D) to determine how many inches above the mantel to place the **lower** Wall Plate holes.

$$(C) + (D) = \text{[ (E) ]}$$

OR

#### Option 2: I want the TV a specific distance above the mantel.

1. Record distance from STEP 2.1 (from pg. 8)

2. Write the specific number of inches you want between the mantel and the TV (or TV with sound bar):

3. Add (C) and (D) to determine how many inches above the mantel to place the **lower** Wall Plate holes.

$$(C) + (D) = \text{[ (E) ]}$$

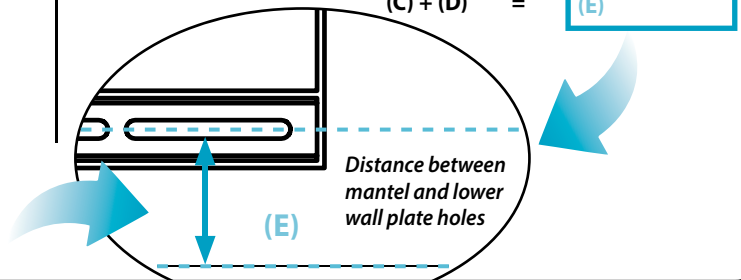

## 2.4

### Find the center of your mantel and the centers of two studs.

Measure and mark the center line of the mantel onto the wall with tape.

Next, use a stud finder to locate two studs, one on each side of the centerline. (If you prefer to use one center stud alone, see "Mount Space" in the Troubleshooting Tips on page 21.)

Then, at the height from either Step 2.2 or 2.3, locate the center of the stud(s) by poking a sharp awl or finish nail through the drywall to find each stud edge. Mark these center spots on the wall. Lag Bolts must be installed into the CENTER of the studs in STEP 3.1.

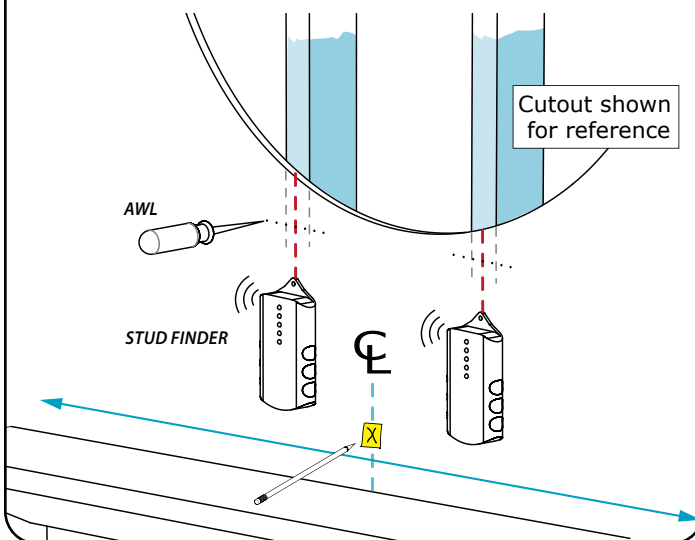

## 2.5

Align the slots on the Wall Plate {32} pointing upwards. Center and level the plate above the mantle and position the height using the table in STEP 2.2. Mark the 4 spots for lag bolts directly on center of the studs.

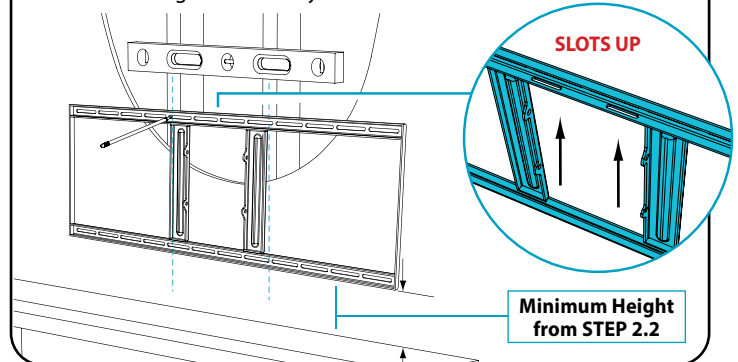

## 2.6

Pre-drill the 4 holes with 7/32" drill bit to a depth of 2.5 inches (65mm) including wall covering.

► Note: Wall covering (drywall) must not exceed 5/8" thickness.

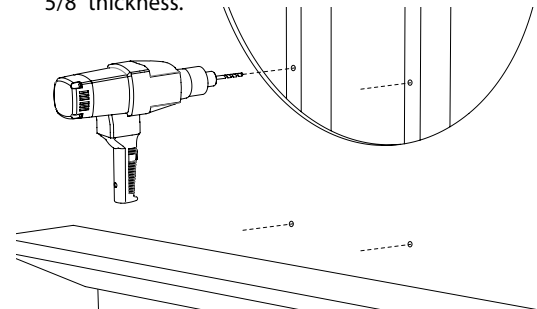



## 2.7

### If necessary, move Wall Plates to clear an outlet.

If a Wall Plate installation is impeded by an electrical outlet (or other) and professionally relocating the outlet is impossible, try one of these two options:

Move Wall Plates up or down to clear the outlet. As long as you don't place the LOWER Wall Plate below the Minimum Distance (Step 2.2) or above the Maximum Distance (step 2.3), MantelMount will still function properly.

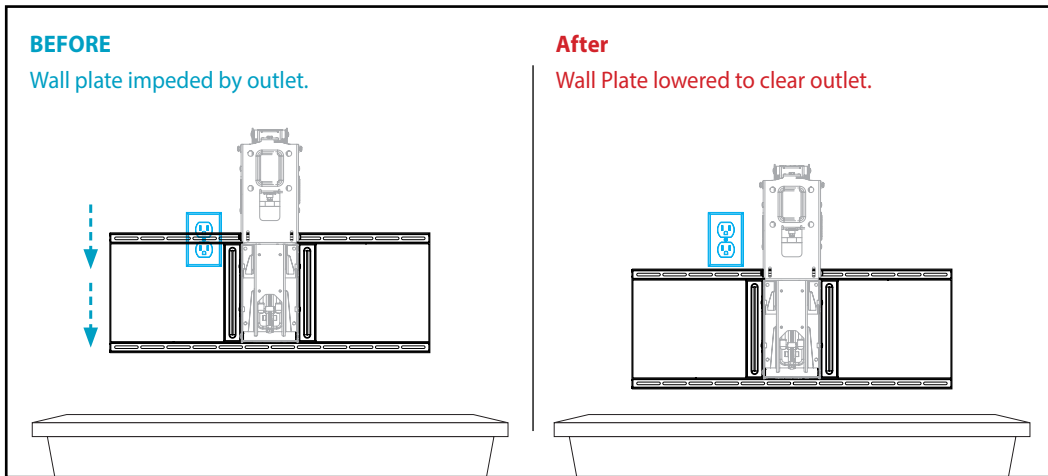

Simply move the Wall Plates up or down enough to clear the outlet, leaving them as close as possible to the originally planned vertical positions.

**IMPORTANT:** You must now move the Vertical Braces {31} on the back of the TV using the same number of inches used to move the Wall Plates (e.g., move the Vertical Braces down 2" if the Wall Plates were moved down by 2"). The bottom of the Vertical Braces must remain between 4 to 10 inches from the bottom of the TV.

► **NOTE:** If outlet is directly behind the Lifting Arm, the only solution is to move the Wall Plates up.

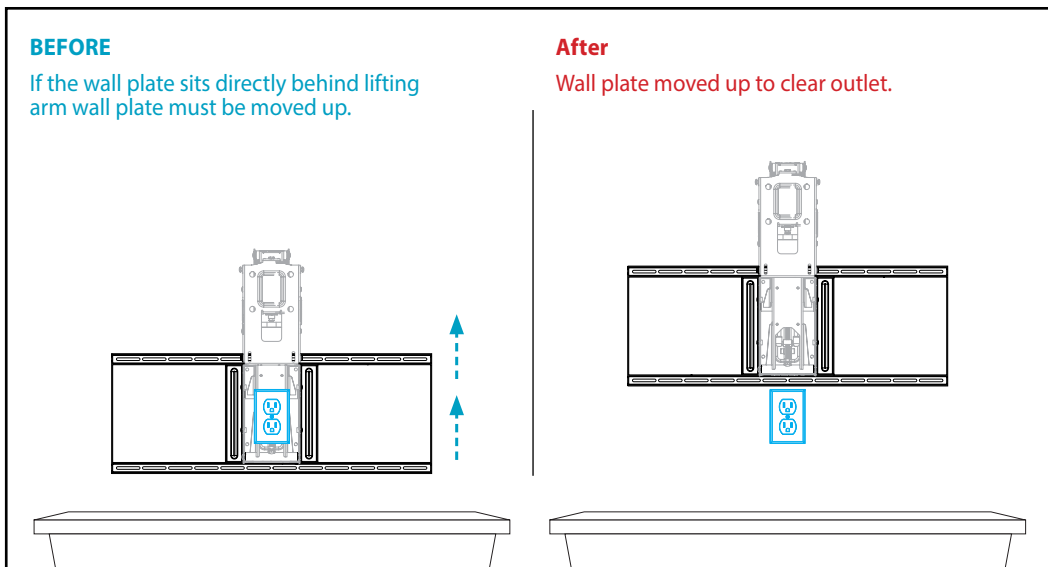

Move the Wall Plates up enough to clear the outlet, leaving them as close as possible to the originally planned vertical positions.

**IMPORTANT:** You must now move the Vertical Braces {31} on the back of the TV using the same number of inches used to move the Wall Plates (e.g., move the Vertical Braces up 2" if the Wall Plates were moved up by 2"). The bottom of the Vertical Braces must remain between 4 to 10 inches from the bottom of the TV.



# STEP 3

## Attach Mount to Wall

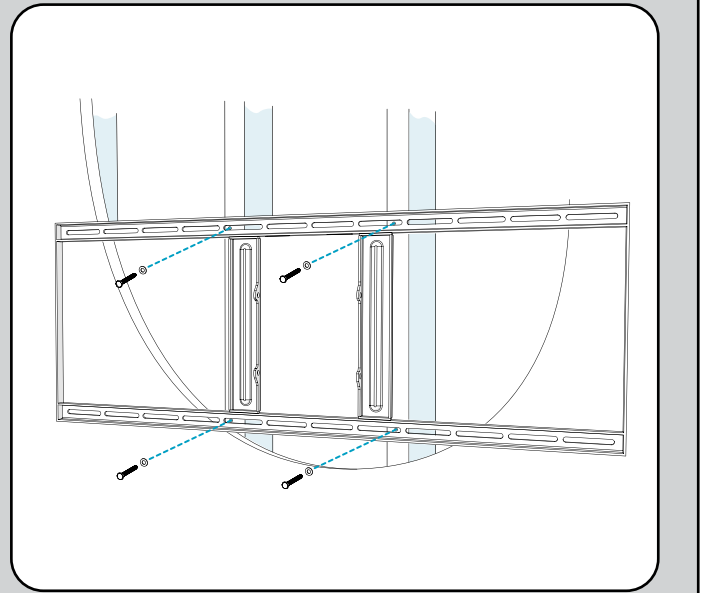

**3.1** Attach the Wall Plate {32} using Lag Bolts {17} and Washers {11} directly into the centers of the studs.

**CAUTION:** Do Not over tighten Lag Bolts {17}. Tighten only until the washers are firmly against the wall plate. Damage due to over tightening can cause property damage or injury.

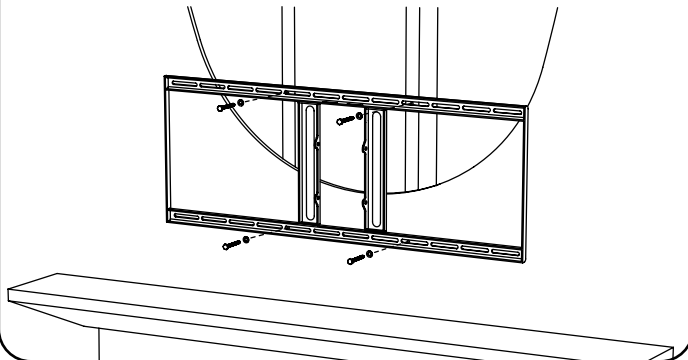

**3.2** Attach the TV Brace {33} to the lifting arm. Level the TV Brace and tighten the 4 screws {15}.

► **NOTE:** After TV is mounted to bracket you may need to adjust these screws to make final Post-Leveling adjustments (Step 5.4).

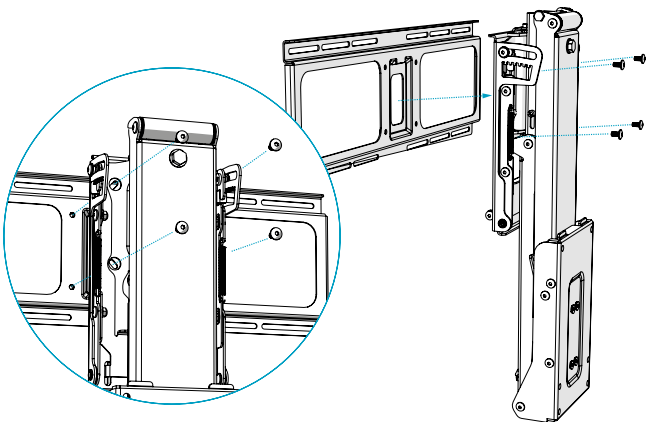

**3.3** Insert top tabs of Lifting Mechanism {35} into the slots of Wall Plate {33} then slide the bottom into position. Align all four holes and install Screws {14}. Insert all 4 screws before tightening securely.

**IMPORTANT:** When handling the Lifting Mechanism {35} DO NOT damage or scratch the rods of the Gas Springs.

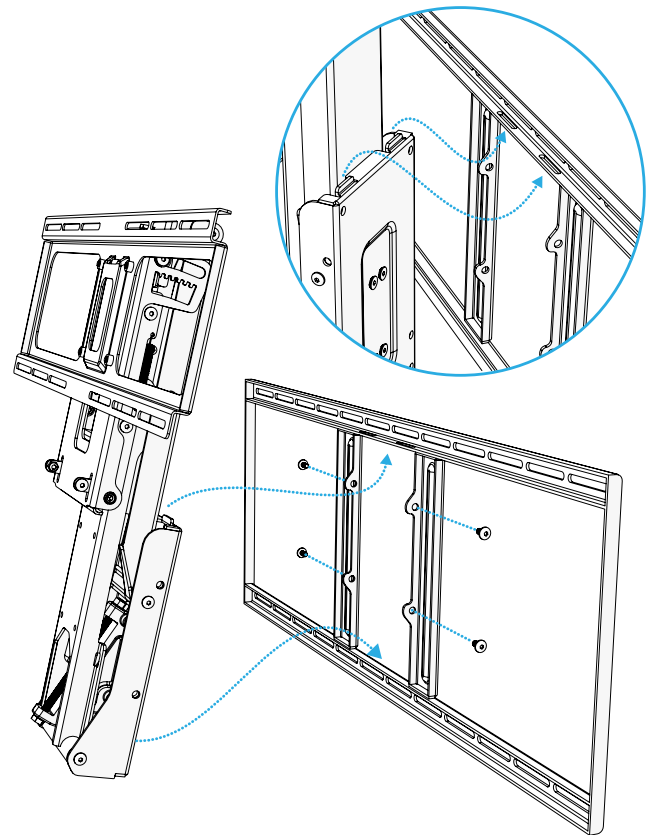

### 3.4



**Engaging the Safety Latches.** In this next step of the installation process you will be required to simultaneously engage the Safety Latches. This will allow you to safely perform the rest of the installation.

**Engaging the Safety Latches will require two people.** The first person must firmly pull down the TV Brace until the Lifting Mechanism is in the horizontal position. **DO NOT HIT THE MANTLE!** The second person must simultaneously lower both of the Safety Latches from the stowed position under the upper lifting arm and into the Latches catch slots. **SLOWLY** raise the TV Brace while at the same time pushing the Safety Latches INWARD and REARWARD until they engage the slots in the Lower Arm. The Lifting Mechanism will now stay at a horizontal position.

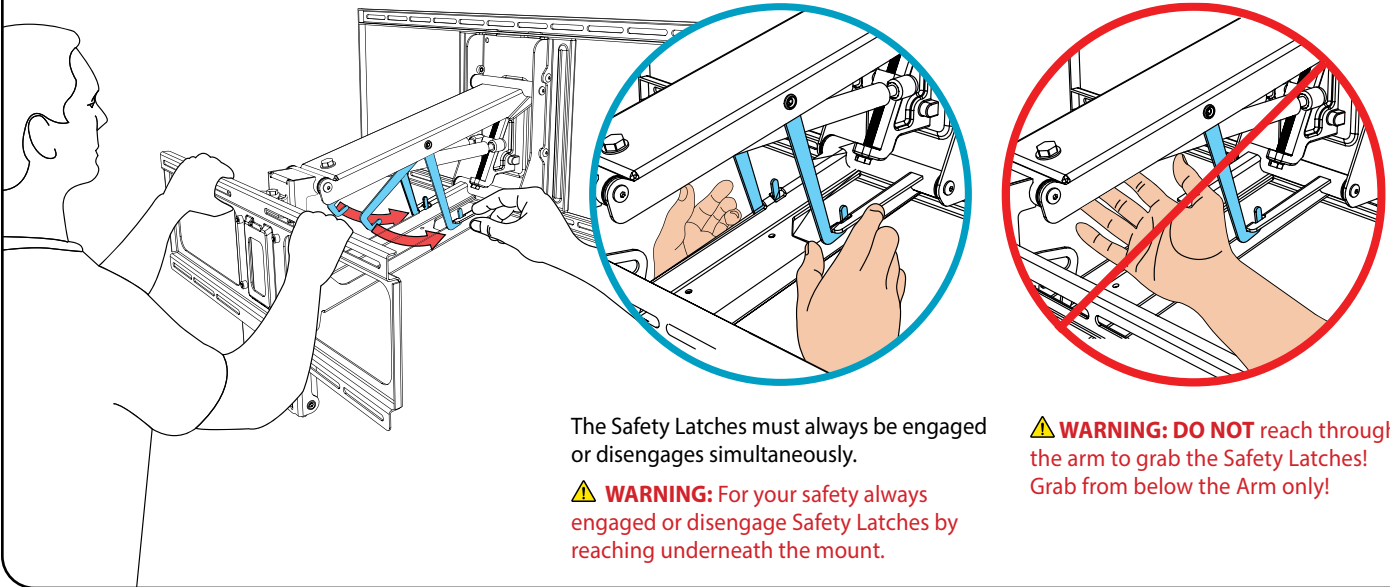

The Safety Latches must always be engaged or disengages simultaneously.

**⚠ WARNING:** For your safety always engaged or disengage Safety Latches by reaching underneath the mount.

**⚠ WARNING:** DO NOT reach through the arm to grab the Safety Latches! Grab from below the Arm only!

## OPTIONAL STEPS AND FEATURES

The following steps are optional. Please review to determine if they are useful to your installation. If not, skip ahead to Section 4.

This step is **OPTIONAL**. **SRE00 NOT REQUIRED IF MOUNTING OVER A FIREPLACE.** If you do not need to add the Side Swivel Kit, skip ahead to Section 4.

**Note:** The SRE00 is recommended only for installations of the MantelMount that require maximum swivel in both Directions, such as a mount that is attached to a post or located at a corner. Also, when the mount is in the stowed, flat position this extender will shift the TV slightly to one side or the other. The wall attachment can be shifted sideways to compensate for this if a center installation is desired.

### SRE00 Swivel Range Extender (Optional)

Before starting this next optional step – **Installing the SRE00 Swivel Range Extender** – You **MUST** pull the Lifting Arm down and engage the Safety Latches. See step 4.1 before proceeding.

#### SRE00 Contents:

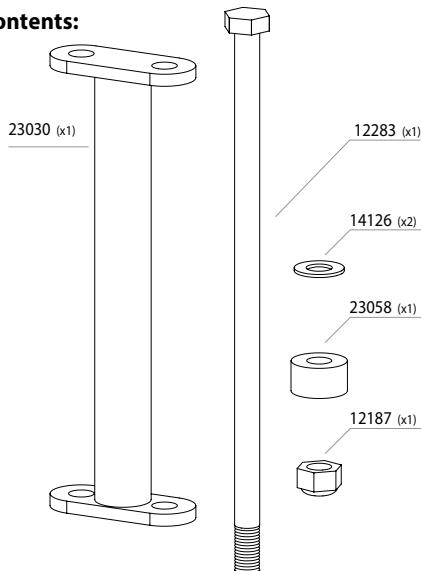

### 3.4

**OPTIONAL**

#### Determine the desired swivel setting.

MantelMount is designed to swivel 30° left and 30° right. Most TVs will reach the wall within this amount of swivel.

For situations where more swivel is desired, the SRE00 Side Swivel Kit that provide 80 degrees in both directions. This situation is only for a small TV and a mounting situation that does not have a mantel.

Note: The Auto-Straightening feature does not work with the SRE00 Swivel Kit. The TV will need to be manually straightened so it's parallel with the wall when raising it to the UP position

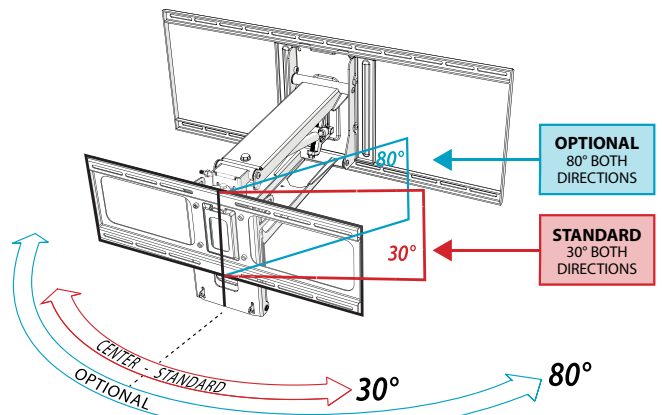

### 3.5

OPTIONAL

**Installing the optional SRE00 Swivel Kit.** Before installing the optional SRE00 Swivel Kit you will first need to pull down the mount and engage the Safety Latch ( **See Step 3.4 before attempting** ). Remove the Swivel TV Plate (Tilting or non-Tilting). You will reuse all of the components. This kit includes a duplicate set of hardware to complete the installation.

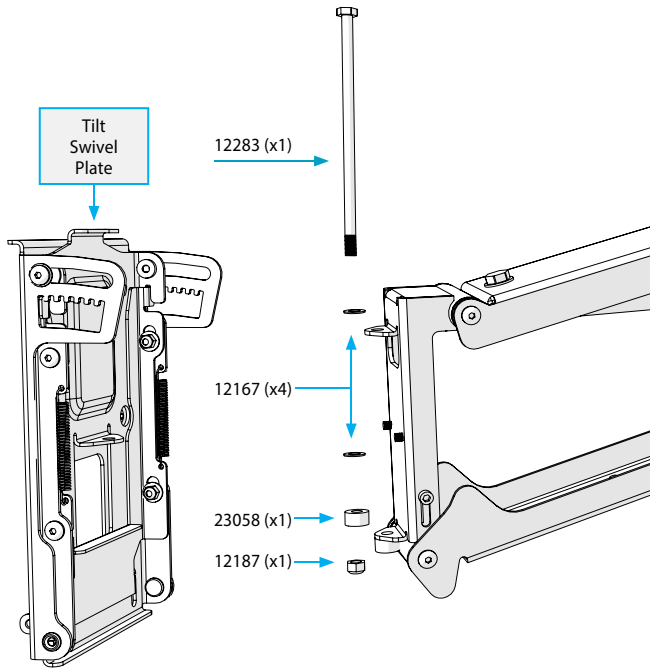

### 3.6

OPTIONAL

Re-assemble the Swivel Plate to the Arm in the order shown here. The Swivel Bridge fits inside the tabs of the Lifting arm and the Swivel Plate

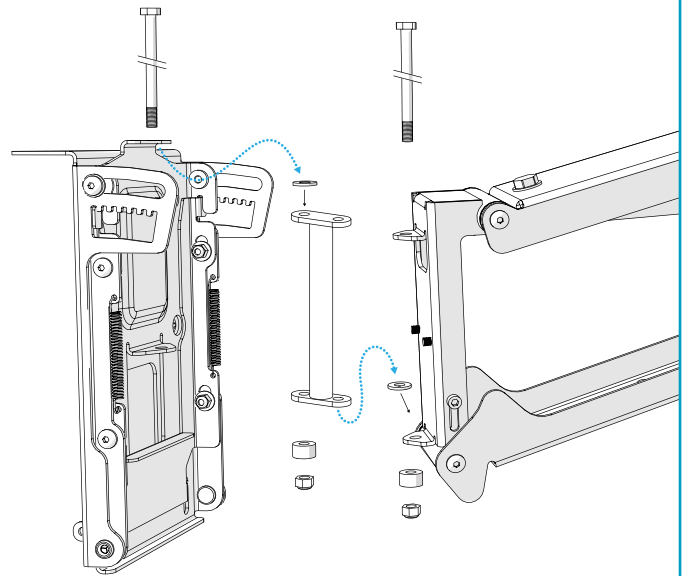

### 3.7

OPTIONAL

Be sure to place one Washer on the lower tab of the lifting arm. The Swivel Bridge will rest on this washer.

Place the other Washer on the top of the opposite side of the Swivel Bridge as shown. The Swivel Plate will rest on this Washer.

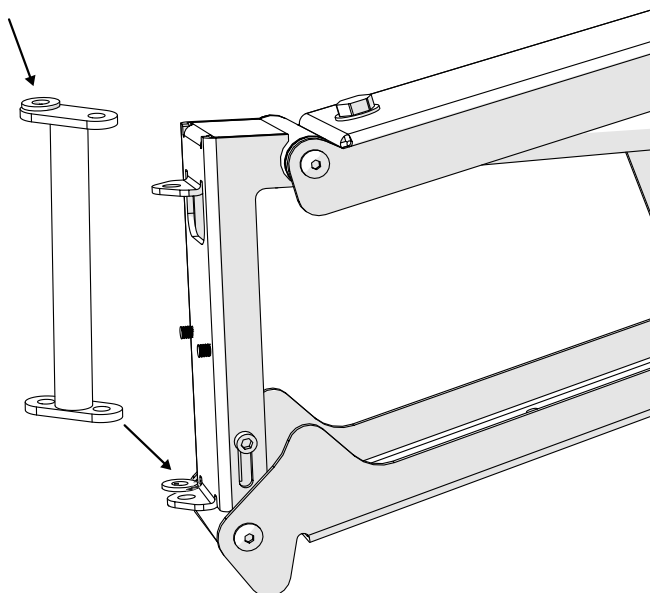

### 3.8

OPTIONAL

Tighten the Locknuts at the bottom until the swivel movement is snug but not tight, so that the TV holds all positions during swivel.

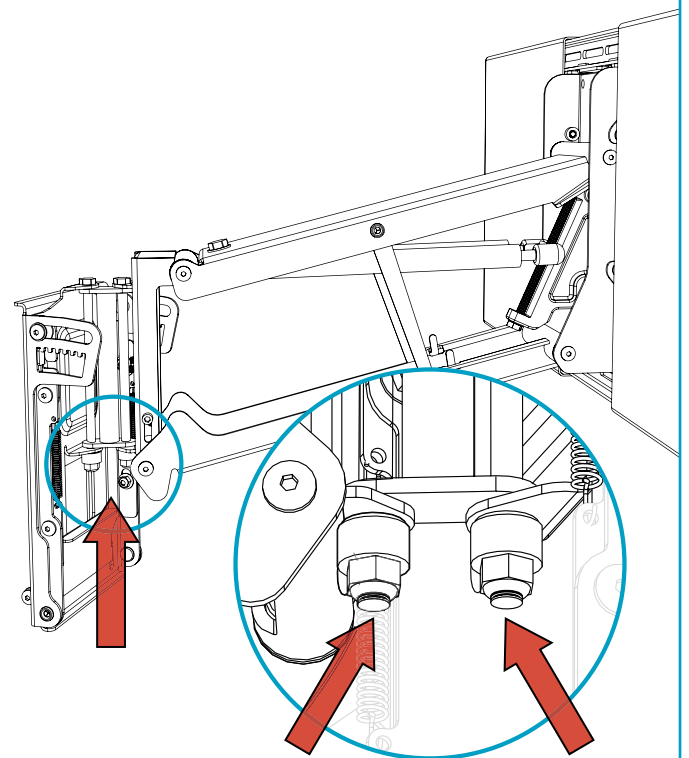

# STEP 4

## Attach TV to Mount

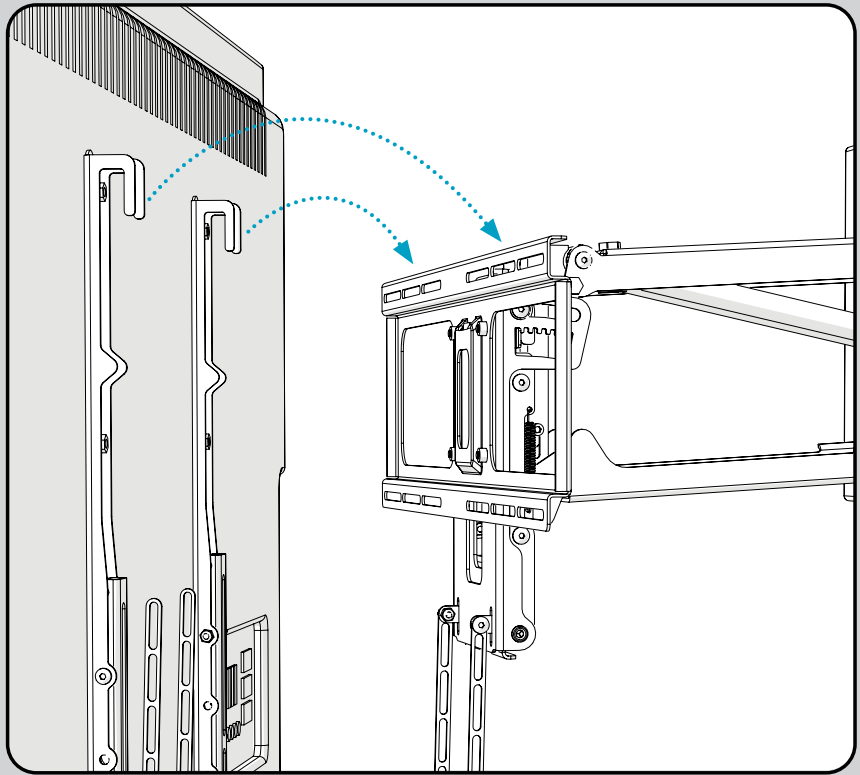

### 4.1

#### Preset the lifting force.

Turn the main bolt **CLOCKWISE** (while looking at the head of the bolt from underneath) as shown to pull the Gas Springs **DOWN** for heavy TVs. Rotate the bolt the other way for less lifting force for lighter TVs.

See the diagram below for a preset estimate for the Gas Springs. The lightest lifting force is at the top, and the heaviest is down just below the middle of the bolt threads.

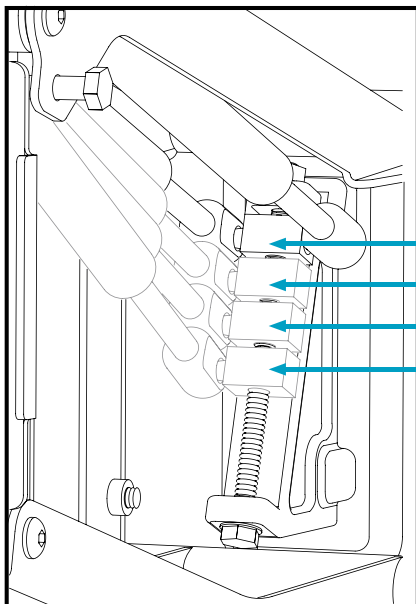

Weight of TV  
25LB  
50LB  
75LB  
100LB

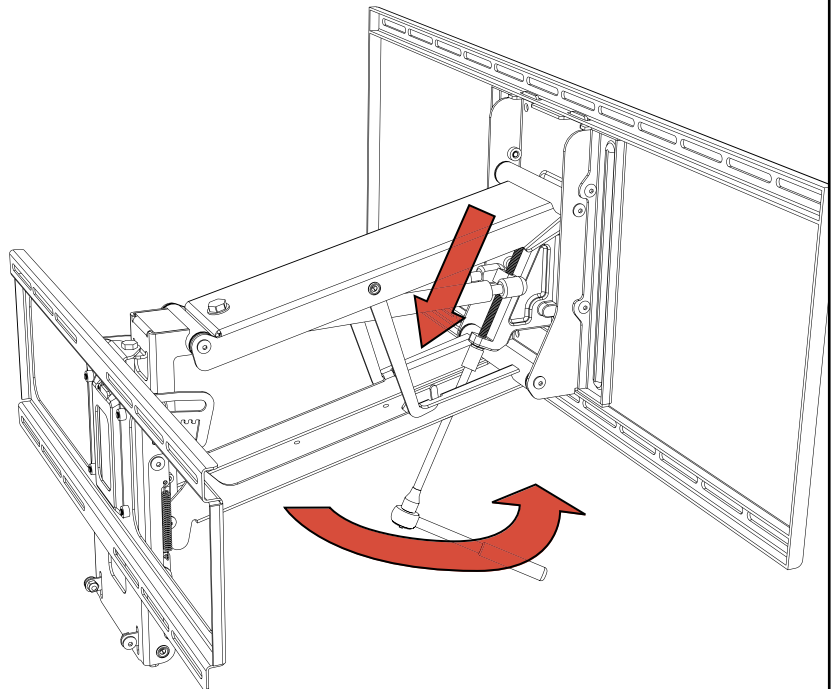

**DO NOT** adjust all the way to the bottom. That position is only to remove the Gas Springs.

## 4.2

### Attaching top tilt linkage .

Attach two hanging Tilt Straps {54} to the front of the Swivel Plate using two Screws {15} and two Nuts {23}. Tighten screws as they will not be accessible after the TV is mounted to the brace. Let the straps hang as we will be attaching them to the rest of the tilt mechanism after the television is attached to the MantelMount.

**NOTE** The tilt function does not work with the Recess Box RB100, because the TV will be too close to the wall. If you intend to use the RB100 Recess Box on with your MantelMount installation **DO NOT** use parts {65} or {54}. You can skip this step.

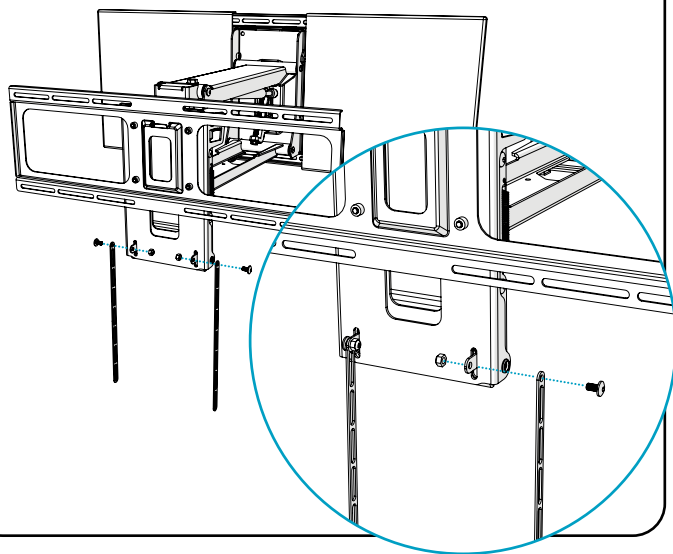

## 4.3

### This step requires two people.



Carefully hang the Television onto the TV Brace making sure that all four hooks on the Vertical Braces {31} engage the TV Brace.

**DO NOT** allow the Television to drop far enough to cause the Lifting Mechanism {35} to hit the mantle.

MantelMount comes pre-adjusted to reduce the possibility of contacting the mantle, but you should always be prepared to remove the television at this stage to make the proper correction.

If the Lifting Mechanism {35} appears to be too close to the mantle, remove television. Go to STEP 5.1 and make an adjustment to the Bottom Stop position. Repeat this process until the Lifting Mechanism is a safe distance from the mantle when the TV is installed.

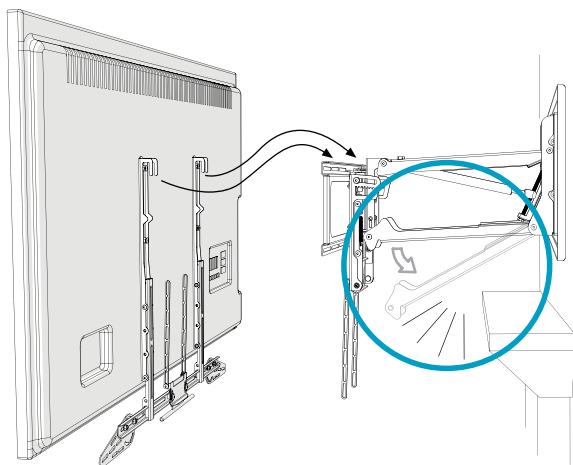

## 4.4

Install 4 Screws {15} through the TV Brace {33} and into the Vertical Braces {31}.

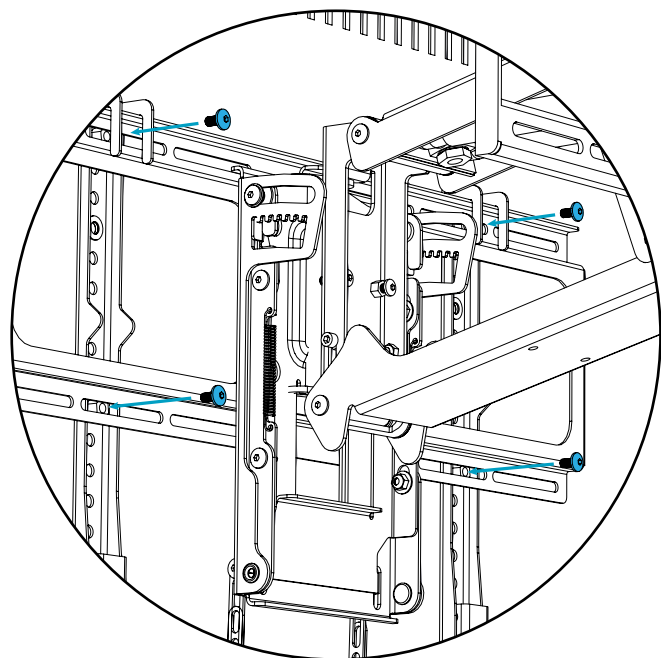

## 4.5

When the lower Tilt Straps {54} are connected to the upper Tilt Straps, the Slots in the Tilt Puller {65} must be centered on its screws, as shown. Hold the Tilt Puller centered until the Tilt Strap screws are tightened.

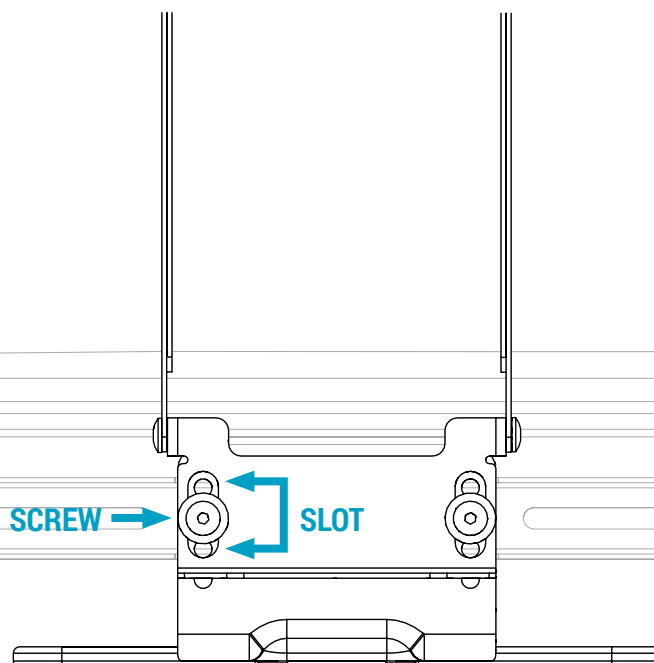

## 4.6

We can now use four Screws {15} and four Nuts {23} to attach the Tilt Straps to the hanging Tilt Straps we attached in step 4.4. When attaching the hardware to the Tilt Straps attach them as close to the end of the straps as your installation allows.

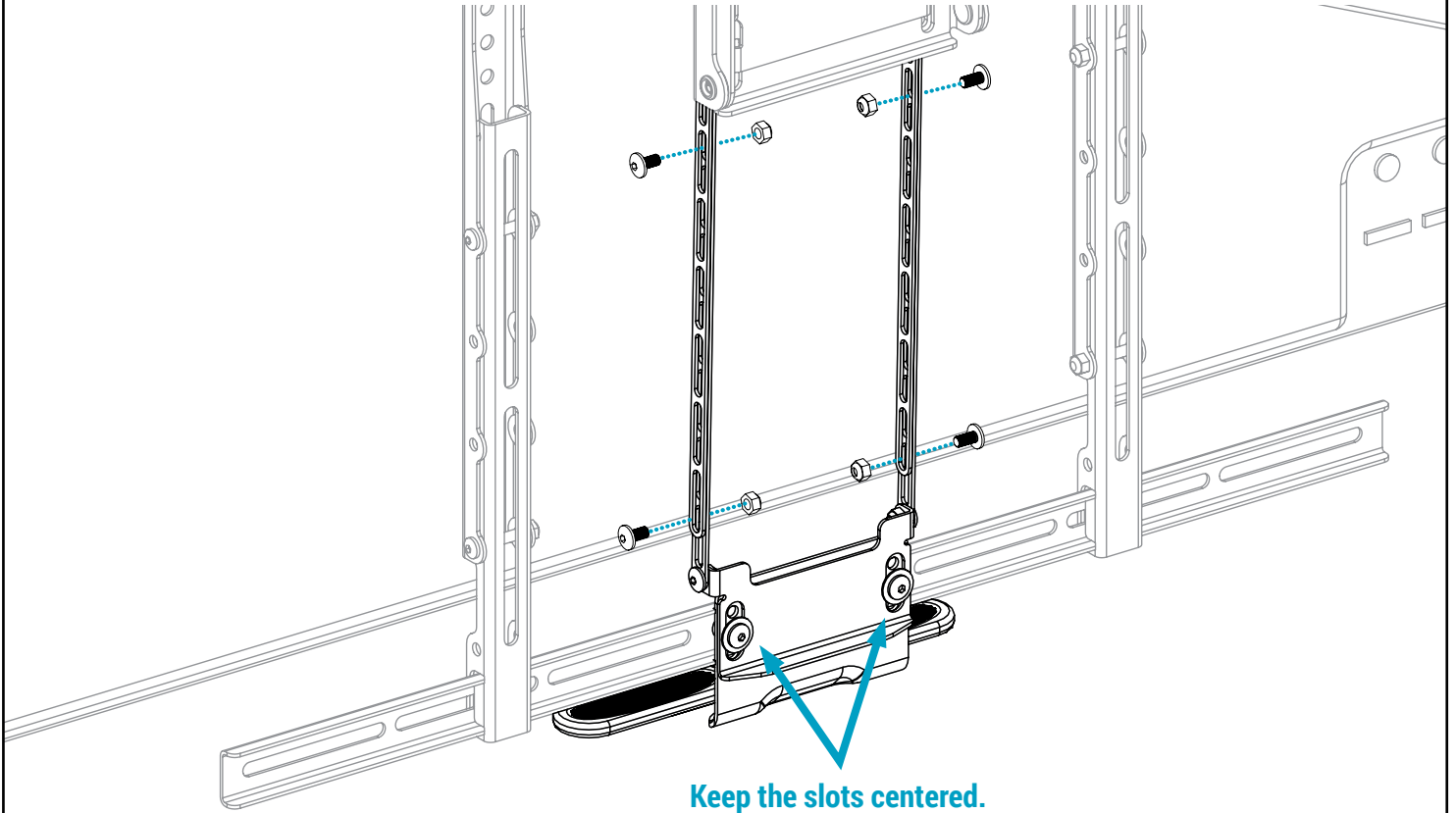

## 4.7

**NOTE:** Using the tilt function on your mount will require the use of both of your hands. You will use one hand to hold the handle steady while pulling the Tilt Puller downward with the other hand. You will feel the locking mechanism disengage from the locked position. You are now free to tilt your mount forward up to 10°. Once you achieve the desired tilt slowly release the Tilt Puller until you feel it reengage the tilt lock mechanism.

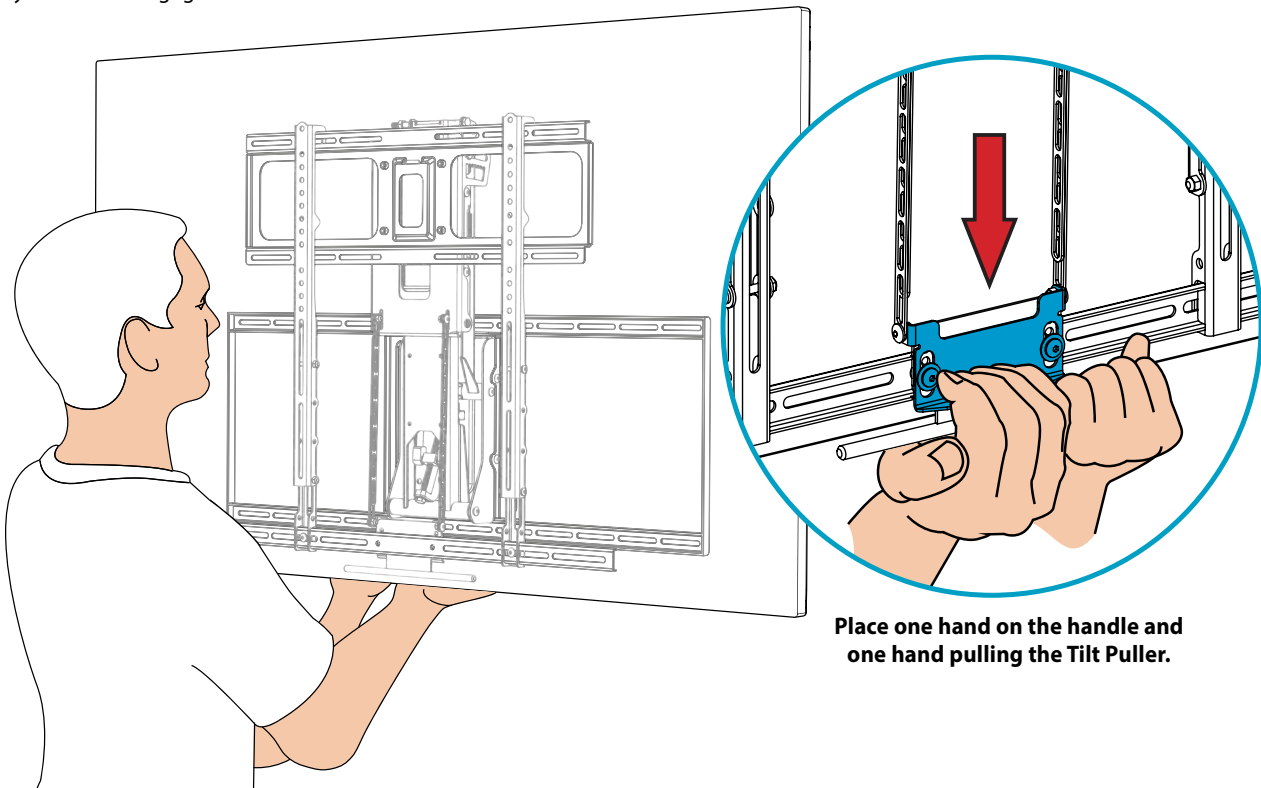



**4.8**

Insert the two Cable Tie Anchors {22} into the two holes in the Lower Arm of the Lifting Mechanism. Press firmly until they are flat.

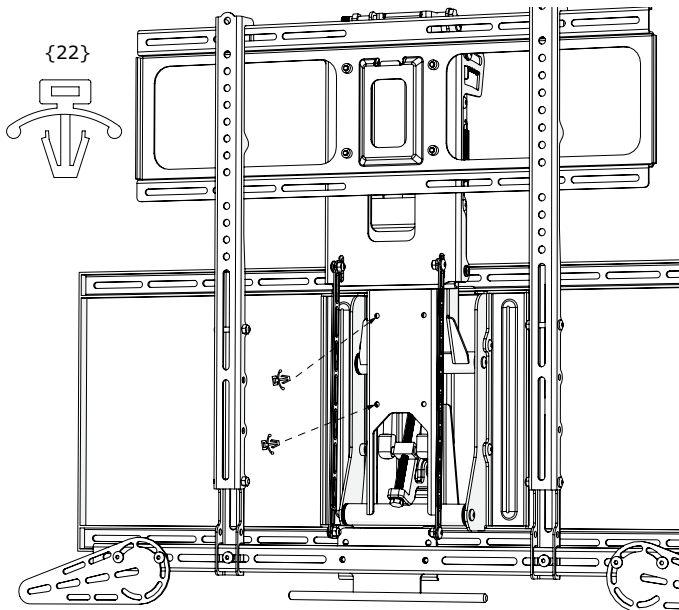
**4.9**

Shown below is the easiest way to attach cables. Use the included Cable Ties {24} to attach cables so they are sideways to the Lower Arm, making a gentle loop.

Cables should be long enough to accommodate the extension and swivel of MantelMount and do not get caught between the lifting arm and the mounting bracket. After check range of motion and cable clearance tightening the Cable Ties.

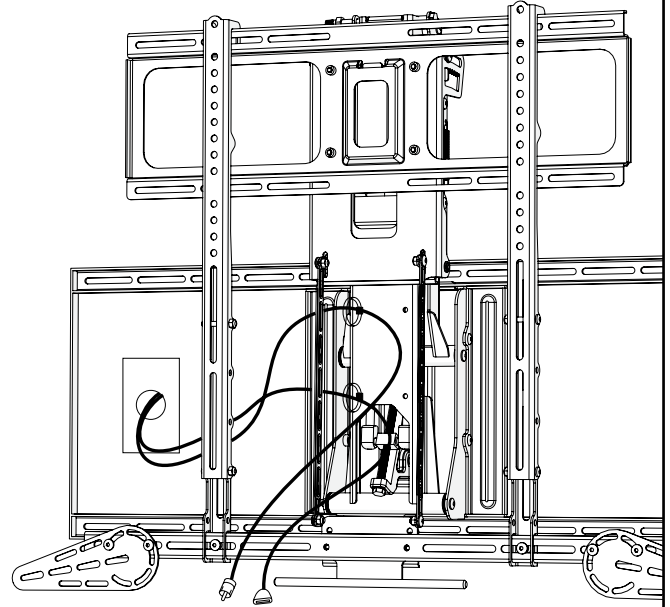
**4.10**

#### Attach the electrical and signal cables to the TV.

Give each segment of the cables extra length so that they are not stressed or kinked when the mount moves.

- ▶ Ensure that cables do not get pinched within the Lifting Arm when the TV is raised.

**Reference Only:** This is one possible configuration for the signal cables. Each segment of the cables has extra length so that the cables are not stressed or kinked when the mount is moved.

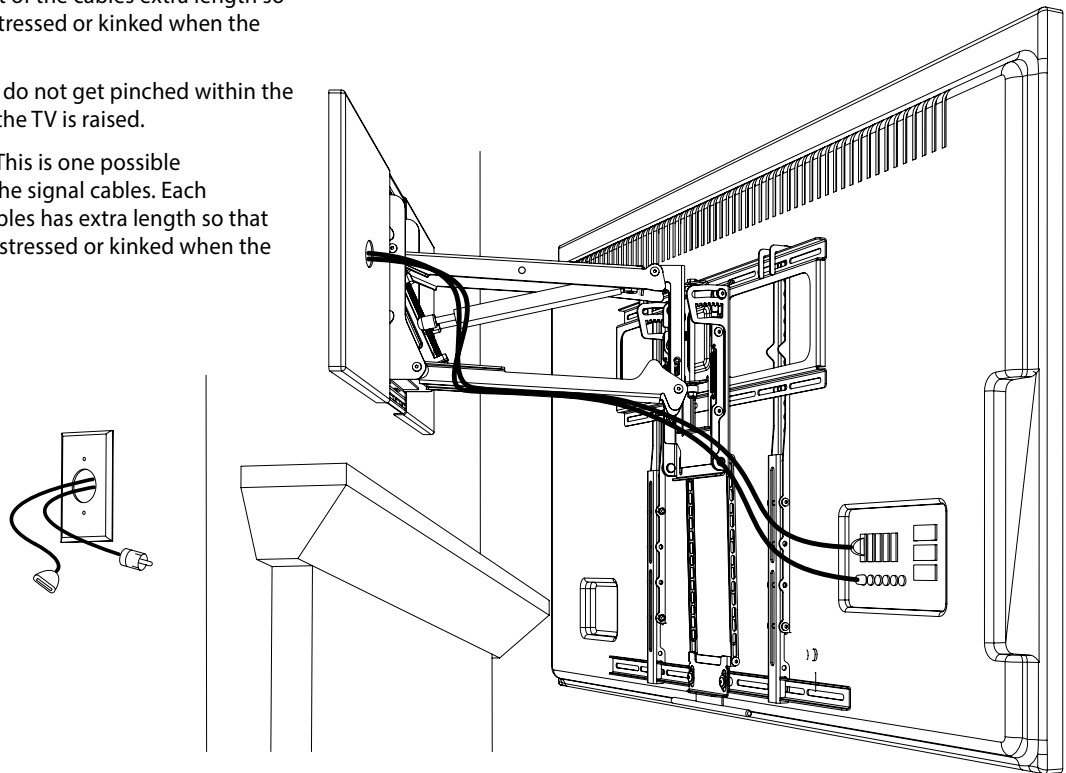



# STEP 5

## Make Final Adjustments

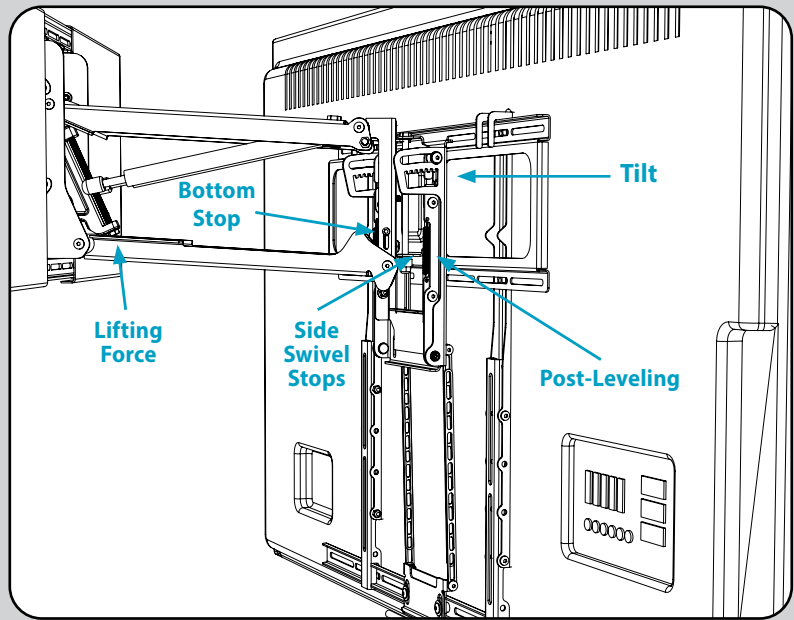

### 5.1 Adjusting the Bottom Stop Position:

Loosen the Locknuts and adjust the Bottom Stop screws to the desired stopping position.

There is one screw on each side of the Lifting Mechanism. Make sure to balance both sides evenly so the TV is level in the DOWN position.

Tighten both Locknuts after the adjustments are made.

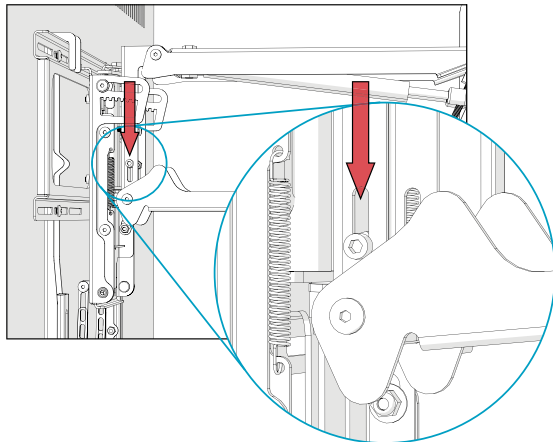
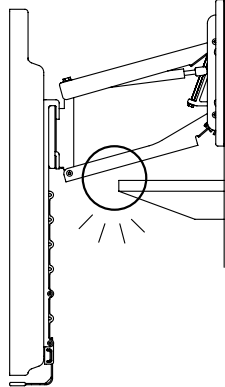

### 5.2 Adjust the Side Swivel Stop positions, if necessary.

To keep the TV from bumping the mantel or wall, loosen the Locknuts {23} and adjust the Swivel Stop Screws to the desired stopping left and right positions. Tighten both Locknuts after the adjustments are made.

- ▶ If no swivel is desired, it may be necessary to remove the Locknuts and reattach them on the other side of the Swivel Bracket so that the Screws can be threaded out to their maximum length.

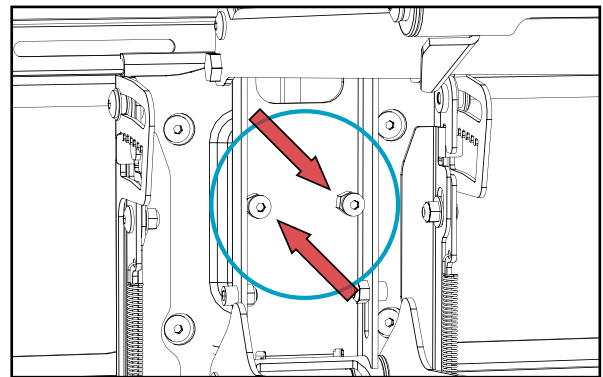
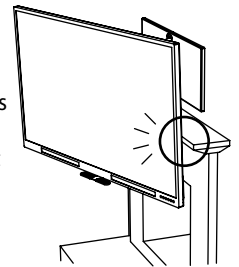

### 5.3 Adjusting for Television weight.

With the Safety Latches Secured in place, use a socket wrench with an extension to adjust the long bolt inside the Lifting Mechanism {35}. Turn the bolt clockwise (AS SHOWN BELOW) to pull the Gas Springs down and increase the lifting force for heavy TVs, or turn counter-clockwise for lighter TVs. This adjustment can take several turns. (Reference Step 4.3)

Adjust the bolt until the TV gently stays in the lowered position. Move the TV up and down within the range below the Safety Latches. The TV should almost stay up against the Safety Latches, but should be easily lowered to the Bottom Stop.

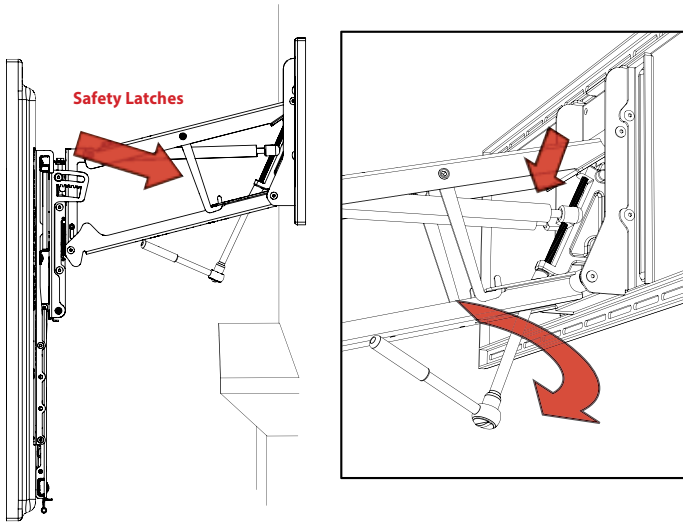

### Verify the proper Lifting Performance (Force)

MantelMount is designed to keep the TV securely in the UP position while also allowing it to gently rest in the DOWN position. Refer to diagram below.

If you need to make adjustments, reinsert the Safety Latches and then repeat STEP 5.3.

- ▶ For more information on refining Lifting Performance, refer to "Mount Performance" in the Troubleshooting Tips on page 26.

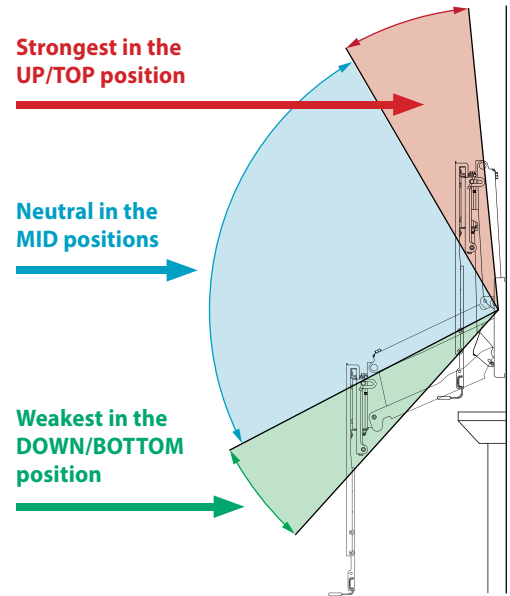

### 5.4 Make Post-Leveling adjustments, if necessary.

Place a level on top of the TV while it's in the UP position. If it's level, the installation is complete! If not, slightly loosen all four Leveling Screws {15} and rotate the TV until it's level and then tighten all the Screws.

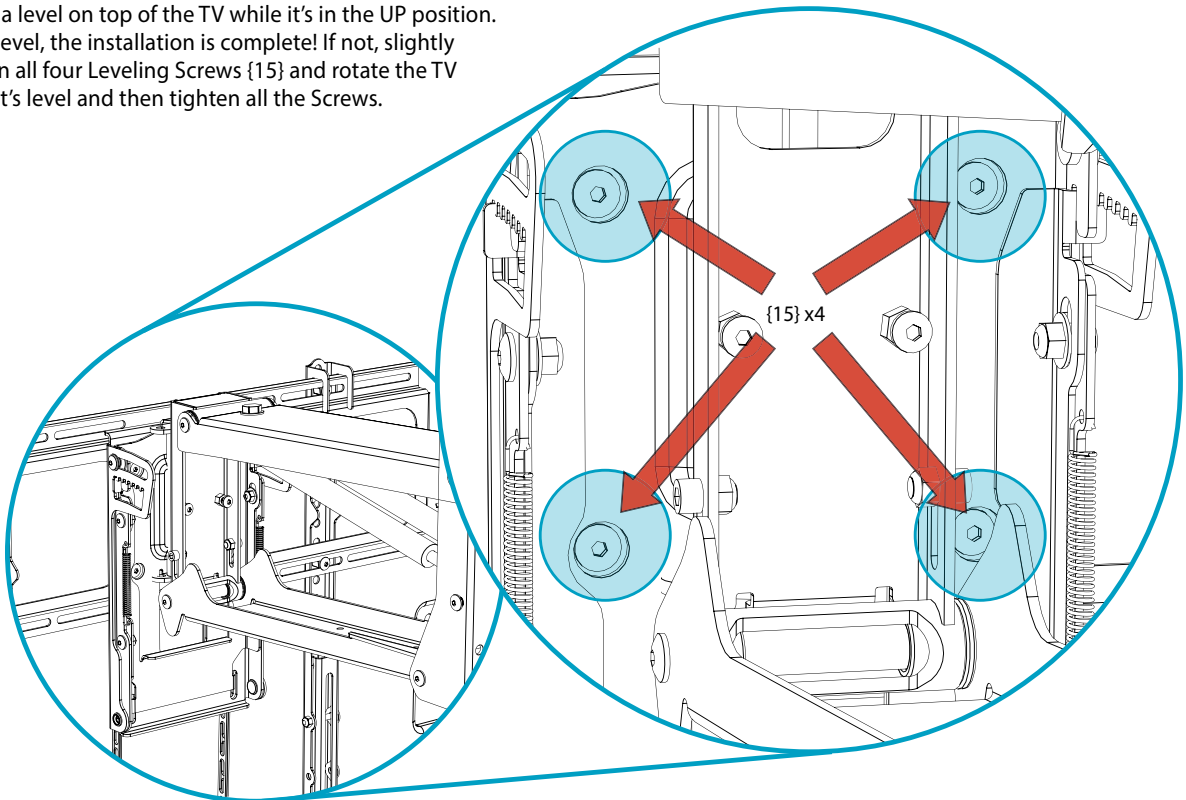

## 5.5

### Adjust the Vertical Tilt Position.

To adjust the forward tilt of your MM720 you will need to reach underneath and behind the Center Handle of the mount and grab the raised edge of the Tilt Puller {65}. Gently pulling down on the Tilt Puller will release it from its locked position. Continue to apply downward pressure to the Tilt Puller while you adjust the TV to your desired tilt position. Once your TV is in the desired position, release the Tilt Puller to lock the tilt into position. The tilt will remain at the same angle while the mount is raised or lowered, unless it is manually changed.

**NOTE** Hold the Handle firmly to maintain control of a heavy TV during the tilting process.

If using the RB100 Recess Box **DO NOT USE THE TILT** when in the stowed position.

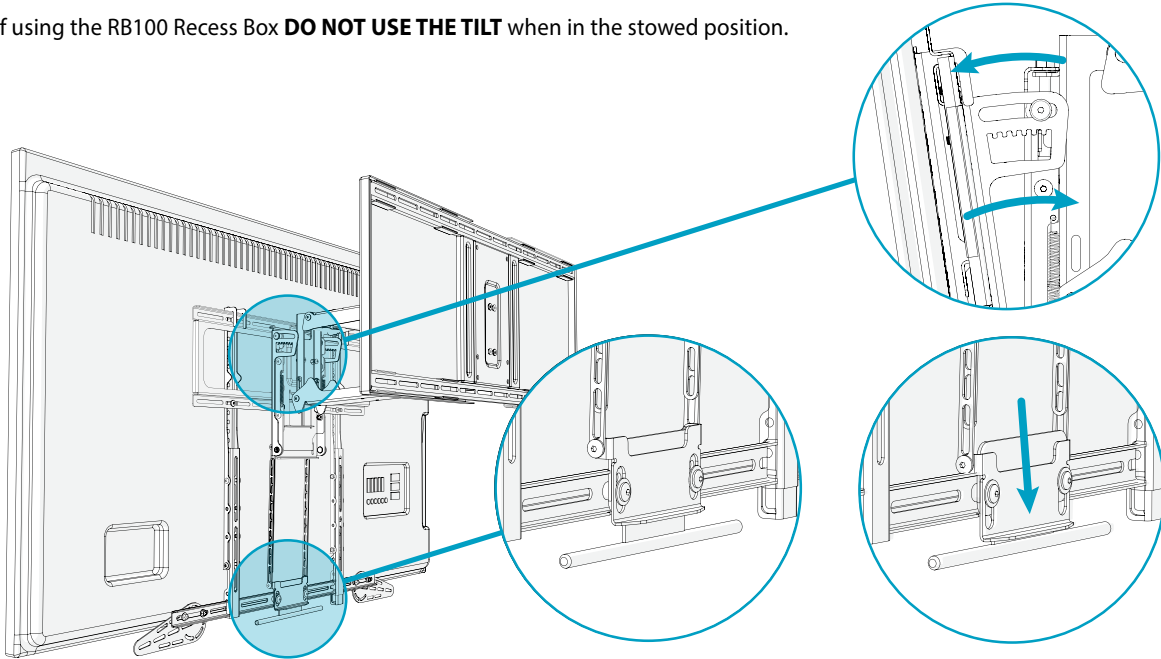

## 5.6

Paint the Wall Covers {29} if desired.

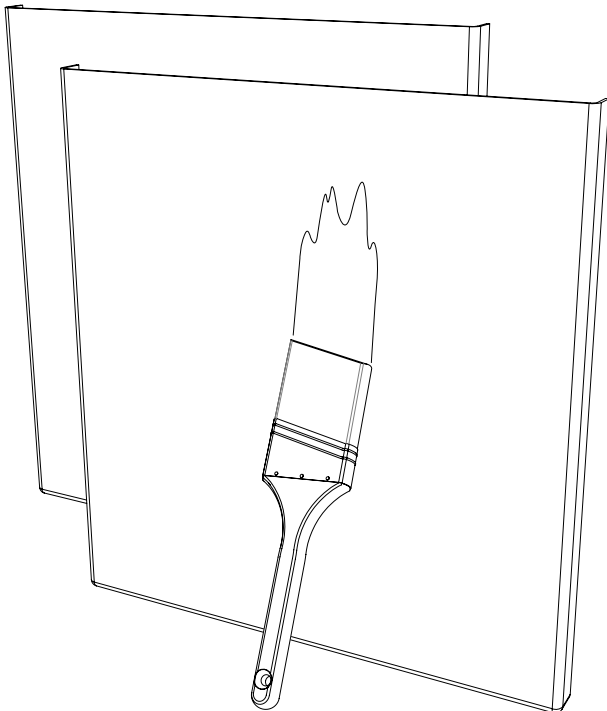

## 5.7

Attach the eight Wall Cover Clips {63} to the wall frame as shown below. These will be used to attach the adhesive Velcro strips that hold the wall covers to the wall frame.

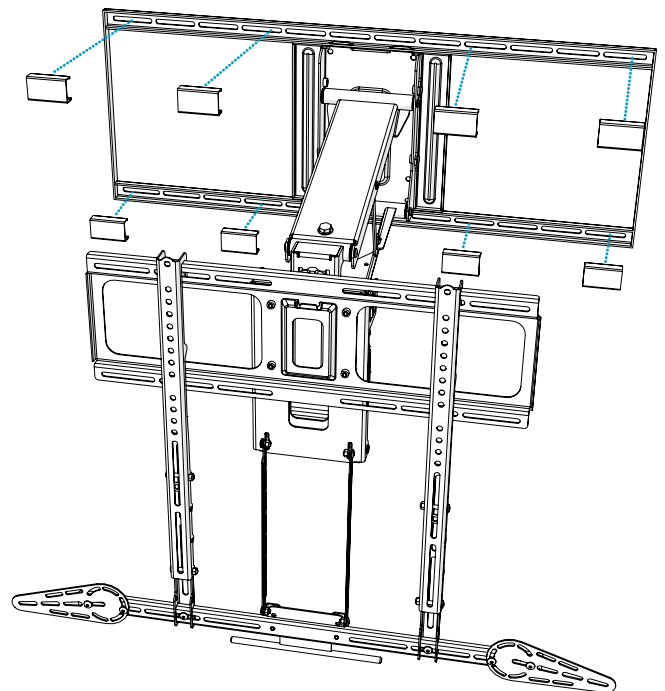

## 5.8

Install the Wall Covers using the included adhesive Velcro strips.

Attach the Hook {25} and Loop {26} strips together onto the Wall Cover Clips, and then press the Wall Covers into the correct position onto the Wall Plate. This will properly align the Velcro onto the Wall Covers.

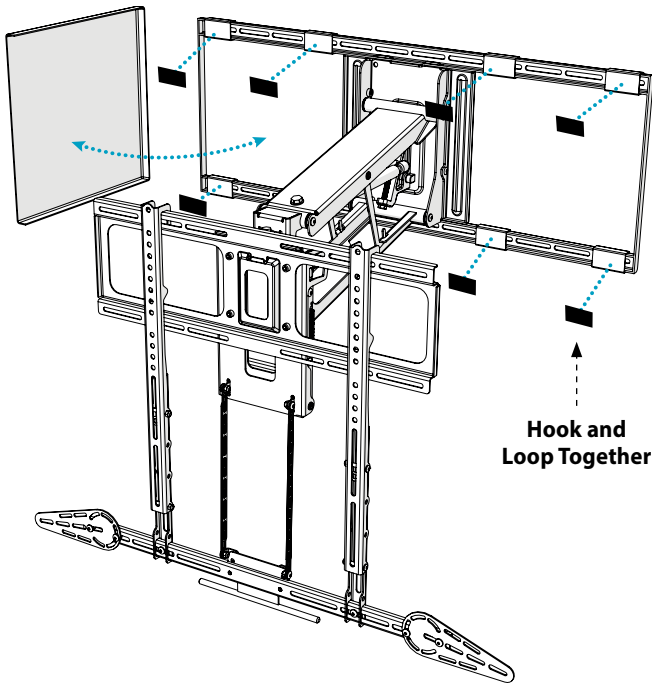

## 5.9

**Removing the Safety Latches.** Gently lower the lifting arm until you feel the Safety Latches disengages from the latch catch slot. While a second person carefully raise the Safety Latches back into the stowed position. Once stowed carefully release the mount.

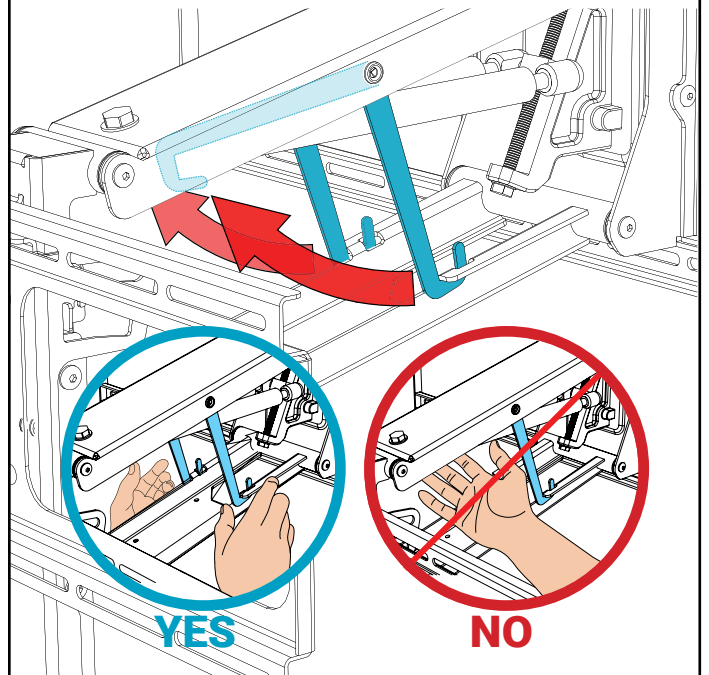

**WARNING:** For your safety always disengage Safety Latches by reaching underneath the mount. **DO NOT** reach through the arm to grab the Safety Latches! Grab from below the Arm only!

## CAUTION

Never release the handle before it is fully upright. MantelMount is strongest in the top position, and allowing it to slam closed can damage televisions. Always control the lifting process.



## CAUTION

Never allow small children to play around or operate the MantelMount. Property damage or personal injury can occur.

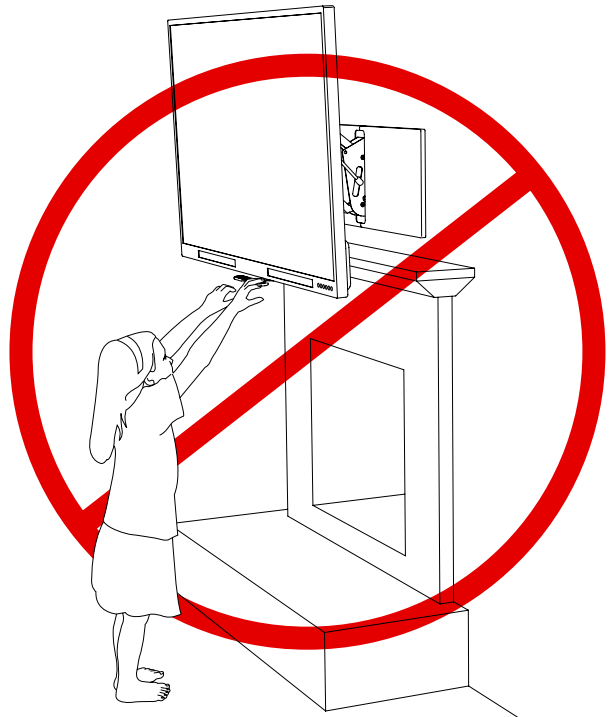

**Customer Service:**  
**(800)-897-9755**  
**www.MantelMount.com**

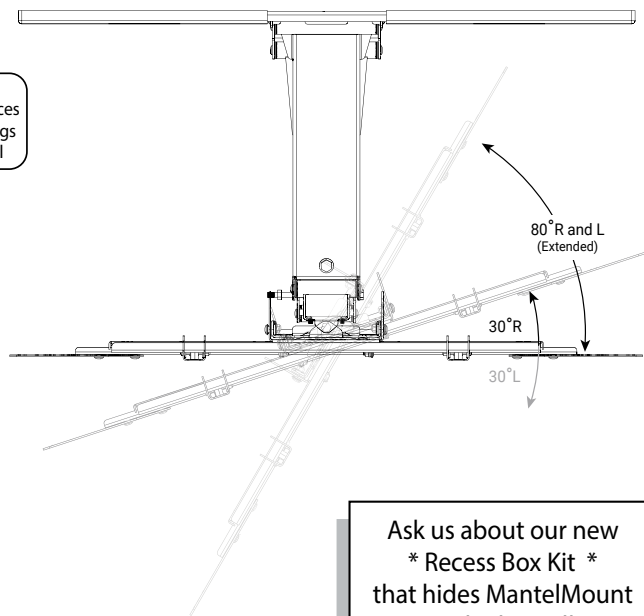
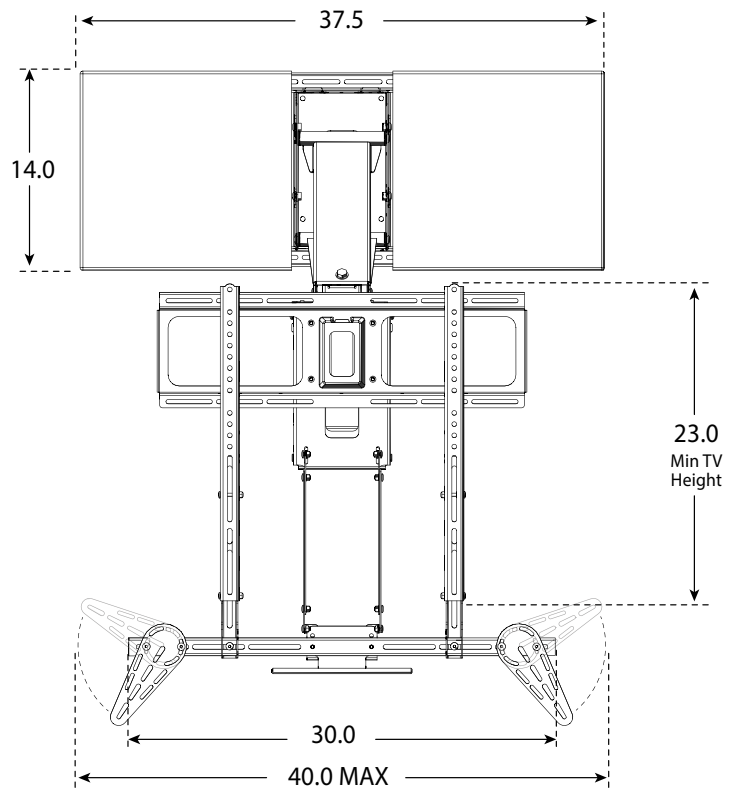
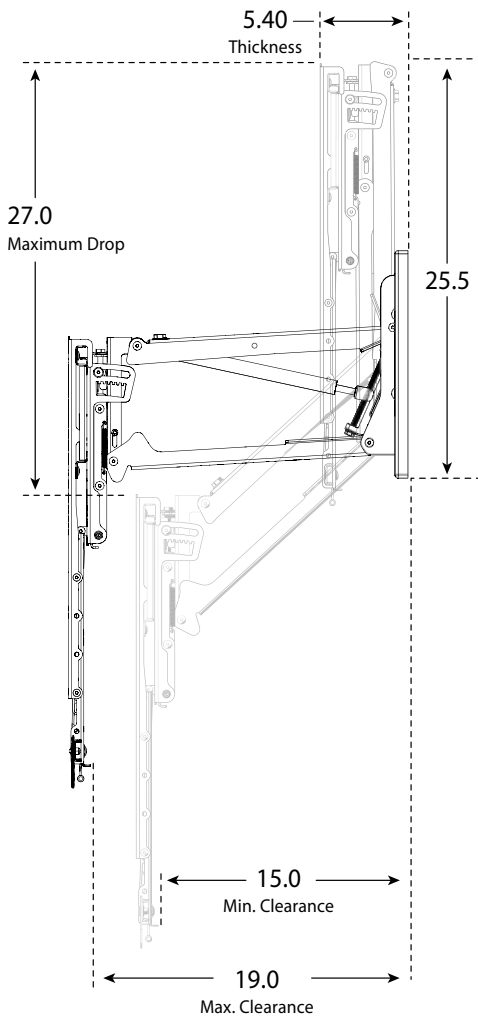

**Exclusive MantelMount Features!**

**Auto-Stabilization:**  
 Pivot automatically balances  
 the force of the Gas Springs  
 so the mount stays level

**Smooth Operation:**  
 Solid shafts with polymer  
 bushings at each pivot point  
 provide silent movement

**Combination pull-down and  
 tilt control** allows you to tilt  
 the television angle forward or back.

**Auto-Straightening:**  
 Flattens the TV as it is raised  
 to the upper position to  
 prevent rotation into the wall

Ask us about our new  
 \* **Recess Box Kit** \*  
 that hides MantelMount  
 inside the wall !



U.S. Pat. No. 8,864,092 - 8,724,037

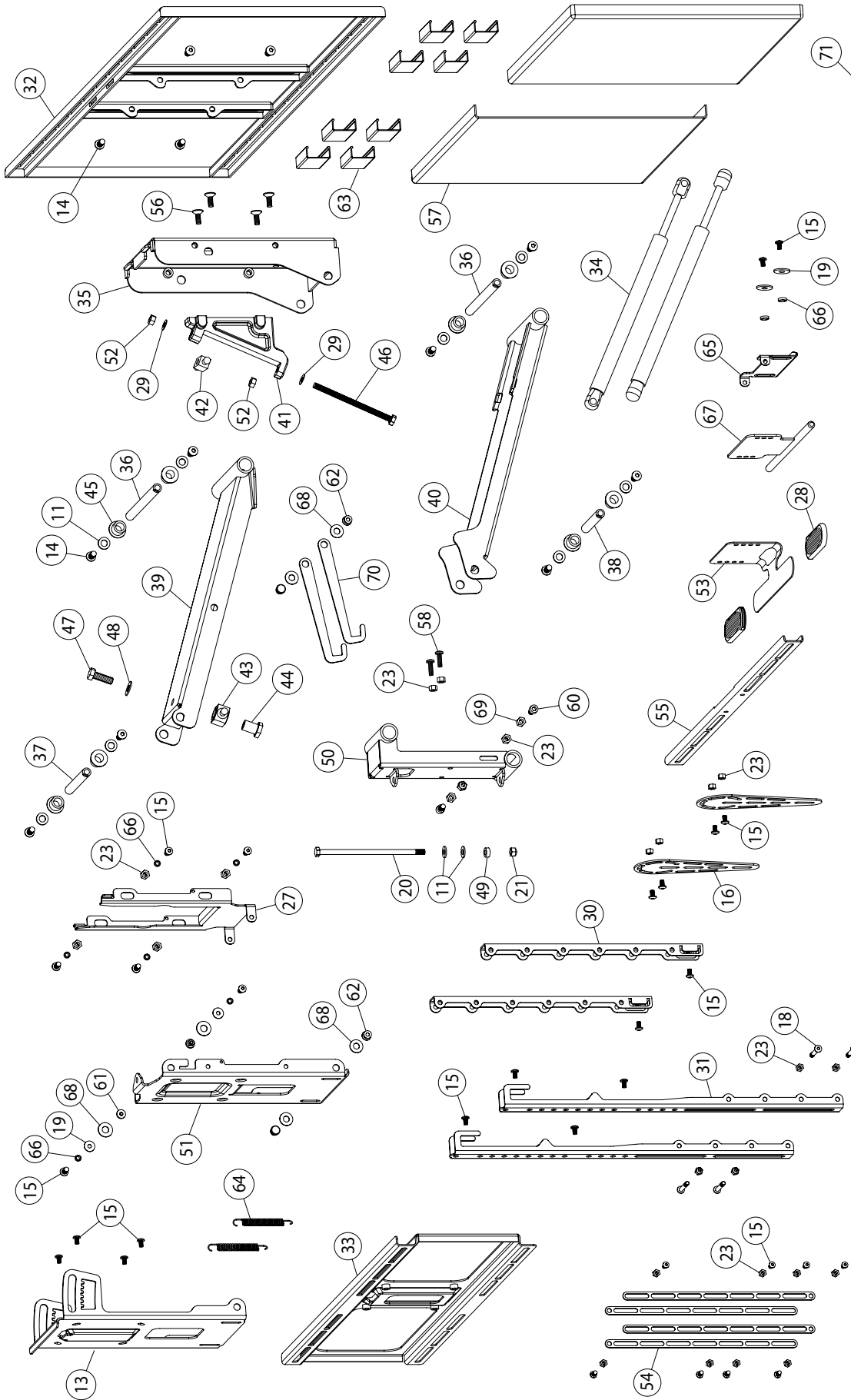

INSTRUCTION MANUAL

Additional Installation Parts

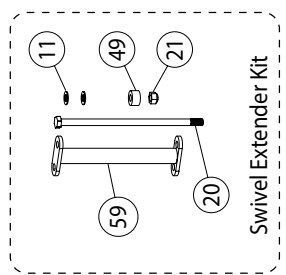
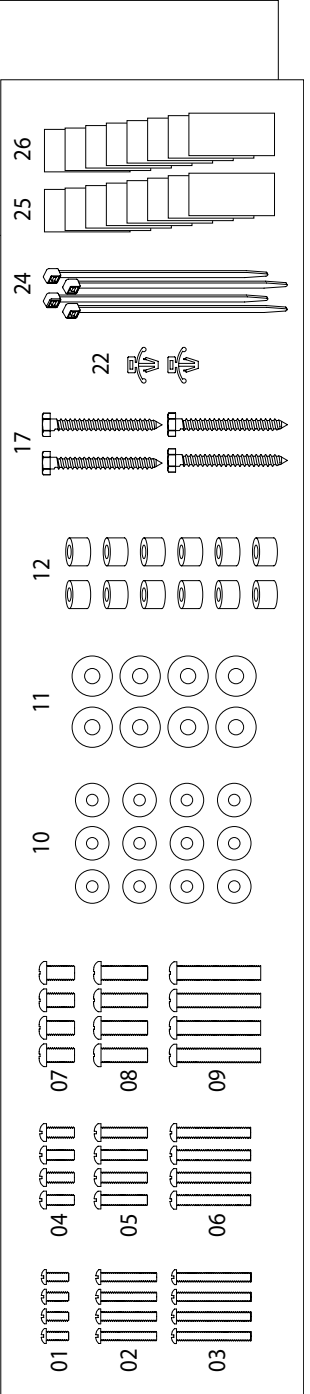



ITEM NO.	PART NUMBER	DESCRIPTION	QTY.
1	12189	M5 x 12	4
2	12190	M5 x 30	4
3	12191	M5 x 40	4
4	12193	M6 x 16	4
5	12194	M6 x 30	4
6	12195	M6 x 40	4
7	12197	M8 x 15	4
8	12198	M8 x 25	4
9	12199	M8 x 45	4
10	12166	Washer M6	12
11	14126	Washer M8 x 2	20
12	12122	Spacer	12
13	23041	Tilting Swivel TV Plate	1
14	12176	Round Head Screw M8 x 16	12
15	12178	Round Head Screw M6 x 10	30
16	15010	SoundBar Wing	2
17	12154	Lag Bolt 60mm	4
18	12255	Round Head Screw M6 x 40	4
19	23055	Washer, M6, 20mm O.D.	4
20	12283	Hex Bolt M8 x 180	2
21	12187	Locknut M8	2
22	14110	Cable Tie Anchor	2
23	12183	Locknut M6	24
24	12162	Tie Wrap	4
25	12139	Velcro Strip HOOK	8
26	12141	Velcro Strip LOOP	8
27	23037	Tilt Pull Latch	1
28	12222	Handle Rubber, Temp Change	2
29	12247	Disk Spring Washer	2
30	14056	TV Brace Extender	2
31	14038	TV Vertical Brace	2
32	23011	Wall Frame	1
33	24030	TV Frame	1
34	12160	Gas Spring	2
35	23013	Wall Bracket	1
36	13064	Shaft 164mm	2

ITEM NO.	PART NUMBER	DESCRIPTION	QTY.
37	13062	Shaft 102mm	1
38	13059	Shaft 89mm	1
39	23018	Upper Arm, Welded	1
40	23020	Lower Arm	1
41	23015	Adjustment Block	1
42	12220	Sliding Block	1
43	13033	Pivot Spring Mount	1
44	12257	Pivot Spring Shaft	1
45	12115	Bushing	8
46	21180	Hex Bolt M8 x 160	1
47	14130	Hex Bolt M10 x 30	1
48	14128	Washer, M10 (10.5 x 21 x 1.5)	1
49	23058	Spacer	2
50	23026	Swivel Bracket	1
51	23039	Swivel TV Plate	1
52	12186	Nut M8	2
53	14062	Center Handle	1
54	23044	Tilt Strap	4
55	14060	TV Horizontal Brace	1
56	23051	Flat Screw M8 x 12	4
57	12113	Wall Cover	2
58	12253	Round Head Screw M6 x 20	2
59	23030	Swivel Bridge	1
60	12174	Cap Screw M6 x 15	2
61	14155	Tilt Nut	2
62	12261	Rivet 10 x 5	4
63	25000	Wall Cover Clip	8
64	23050	Spring	2
65	23047	Tilt Pull Handle	1
66	23010	Spacer	8
67	23023	Center Handle, Hidden	1
68	23033	Washer, M10, (10.2 x 22 x 1.0)	6
69	12185	Nut M6	2
70	23052	Safety Hook	2
71	MM720M	Instruction Manual	1



# TROUBLESHOOTING TIPS

## Customer satisfaction is our top priority!

Following are solutions for the most common installation challenges. For further assistance, visit [www.mantelmount.com/troubleshooting](http://www.mantelmount.com/troubleshooting) or contact Customer Support at 1-800-897-9755 ext.1 or [support@mantelmount.com](mailto:support@mantelmount.com), Monday through Friday, 7am to 4pm PST.

► **NOTE:** In rare cases, one troubleshooting adjustment may create the need for another. Be prepared for some trial and error.

MOUNT SPACE	
ISSUE	SOLUTION
<b>The wall covering is made of brick or stone.</b>	It's possible to install MantelMount by using concrete anchors (included) with the Lag Bolts {17}, PROVIDED the brick/stone/wall is structurally sound, several inches thick, and can handle four times the weight of the TV and mount. <b>Working with a concrete/masonry professional for this type of installation is recommended.</b>
<b>The drywall/stucco wall covering is thicker than 5/8".</b>	Please contact Customer Support for guidance before attempting installation.
<b>A single wood stud is centered on my wall.</b>	It's OK to mount the Wall Plates to a single stud by driving two Lag Bolts through the center of the Wall Plates and into the center stud, as long as the Lifting Arm ends up positioned directly in front of the stud. Alternatively, for a smaller footprint, replace the Wall Plates with the SSB40 Single Stud Adapter, available at <a href="http://MantelMount.com">MantelMount.com</a> . <b>Note:</b> SSB40 Single Stud Adapter for use with the MM340 & MM540 only
MOUNT PERFORMANCE	
ISSUE	SOLUTION (May require some trial and error to reach optimal performance.)
<b>The Lifting Arm won't pull down in order to secure the Safety Latches.</b>	It will take some force to pull down the Lifting Arm when it's in the raised position and there is no TV attached. As long as the mount is securely attached to a stud(s) in the wall, it won't break. First, make sure the TV Brace is attached to the Lifting Arm ( <b>see Step 3.3</b> ). Next, pull the Lifting Arm down: Stand in front of the mount, reach up and grasp the top or bottom of the TV Brace with both hands, palms facing down. Move one foot back for leverage and straighten elbows. Then lean back, bend both knees and elbows, and pull the mount out and down ( <b>see Step 4.1</b> ).
<b>TV is difficult to pull down.</b>	Use the <i>MantelMount Three-Step Pull-Down Technique</i> : <ol style="list-style-type: none"> <li>1. Stand in front of the mount, arms extended with palms up and elbows straight.</li> <li>2. Firmly grasp the lifting handles and lean back slightly with one foot forward and one foot back.</li> <li>3. Step backward with forward foot to pull the mount away from the wall while placing downward pressure on the handles (keep elbows extended).</li> </ol> <p>If the mount is still difficult to pull down, review <b>Step 5.1</b>, make slight counterclockwise adjustments to the Lifting Force, and try again. The goal is to adjust the Lifting Force just enough to comfortably pull the TV down without overcompensating. If it becomes too easy to pull down, it may also become difficult to lift up. Give it a few practice runs, but be prepared for a little trial and error.</p>
<b>TV is difficult to lift up.</b>	If the mount is relatively easy to pull down, slightly tighten it when it's in the UP position. Review <b>Step 5.1</b> to make minor clockwise adjustments to the Lifting Force, then try lifting up the TV again. The goal is to adjust the Lifting Force just enough to comfortably lift the TV without too much effort. However, if it becomes too easy to lift up, it may become difficult to pull down. If you are unable to find a balance between ease of pulling down and lifting up, follow the instructions above and focus primarily on making it easier to pull down. Then make adjustments to the Bottom Stop positions ( <b>see Step 5.3</b> ). Lower the Bottom Stops to limit downward travel. The less downward travel, the easier it will be to lift.
<b>The mount won't remain stationary anywhere along the route of travel.</b>	Make adjustments to the Lifting Force ( <b>see Step 5.1</b> ). The combination of the TV's size and weight, installation height and mantel depth may affect whether the TV can rest at various positions along the route of travel. What's most important is that the TV can comfortably pull down/lift up and stop at the optimal viewing height.
<b>TV is not lowering the full vertical travel listed in the specifications.</b>	If you can comfortably pull down and lift the TV but would like for it to drop below the lowest Bottom Stop Position, remove the Bottom Stop Screws on each side ( <b>see Step 5.3</b> ); the TV will travel even lower. However, proceed with caution. If the TV is above a mantel, removing the Bottom Stop Screws may cause the Lifting Arm to hit the top of the mantel.

CONTINUED ON NEXT PAGE →

# TROUBLESHOOTING TIPS

← CONTINUED FROM PREVIOUS PAGE

MOUNT PERFORMANCE			
ISSUE	SOLUTION (May require some trial and error to reach optimal performance.)		
<b>TV is tilting forward when in the UP position.</b>	This is generally an indication that the Lifting Force is not set tight enough in the UP position ( <b>see Step 5.1</b> ). Slightly turn the Tension Bolt clockwise and try again. The goal is to adjust the Lifting Force just enough for the TV to no longer tilt in the UP position. Be careful not to set the Lifting Force too tightly in UP position or the TV may not fully lower to the optimal viewing position.		
TV LEVELING			
ISSUE	POSSIBLE CAUSE	HOW TO CHECK	SOLUTION
<b>TV is not level in the UP and/or DOWN positions.</b>	The mantel, ceiling or floor may not be level.	Compare TV level with that of the mantel and floor.	<ol style="list-style-type: none"> <li>1. Adjust until visibly satisfactory.</li> <li>2. Pull down the TV.</li> <li>3. Make Post Leveling adjustments (<b>Step 5.6</b>) and match the level readings of the mantel with the TV.</li> <li>4. Make additional adjustments as shown in <b>Step 4.3</b> and <b>Step 5.3</b> if needed.</li> </ol>
	Vertical Braces aren't evenly attached.	Look at the back of the TV and ensure that the top of the Vertical Braces are parallel to one another.	<ol style="list-style-type: none"> <li>1. Secure the Safety Latches (<b>Step 4.1</b>).</li> <li>2. Detach the TV Brace from the Vertical Braces (<b>Step 4.4</b>).</li> <li>3. Remove electrical and signal cables (<b>Step 4.5</b>).</li> <li>4. Remove the TV from the TV Brace (<b>Step 4.2</b>) and lay TV face down on a blanketed surface (<b>Step 1.1</b>).</li> <li>5. Remove the Vertical Brace(s) as necessary.</li> <li>6. Reposition the Vertical Braces so that they are properly parallel to one another, then repeat <b>Step 1</b>, <b>Step 4</b> and if necessary, <b>Step 5</b>.</li> </ol>
	Wall Plates aren't level.	Use a level on top of Wall Plates to verify that it's not level.	<ol style="list-style-type: none"> <li>1. Secure the Safety Latches (<b>Step 4.1</b>).</li> <li>2. Detach TV Brace from Vertical Braces (<b>Step 4.4</b>).</li> <li>3. Remove electrical and signal cables (<b>Step 4.5</b>).</li> <li>4. Remove the TV from the TV Brace (<b>Step 4.2</b>) and lay TV face down on a blanketed surface (<b>Step 1.1</b>).</li> <li>5. Slightly loosen all four Lag Bolts (<b>Step 3.4</b>).</li> <li>6. Adjust Wall Plates so that they are level.</li> <li>7. Hold Wall Plates in level position and firmly tighten the four Lag Bolts. Heed warning in <b>Step 3.4</b>.</li> <li>8. Once the Wall Plates are level, repeat <b>Steps 3, 4</b> and <b>5</b>.</li> </ol>
<b>TV is level in the UP position, but unlevel in the DOWN position.</b>	The Bottom Stops aren't evenly set.	Use a level to verify the TV is level in the UP position but not in the DOWN position.	Follow the instructions in <b>Step 5.3</b> . Be prepared for some trial and error. If adjusting the Bottom Stops doesn't solve the problem, try the solution below for when a TV is heavier on one side.
	TV is heavier on one side.	Use a level to verify the TV is level in the UP position but not in the DOWN position.	Attach a counterweight to the back of the TV. Contact Customer Support for assistance.
<b>TV is level in the DOWN position, but unlevel in the UP position.</b>	Post-Leveling Adjustments haven't been made.	Use a level on top of the TV to verify it's leveled in the DOWN position but not in the UP position.	Refer to <b>Step 5.6</b> and make adjustments.



For missing/damaged parts or questions during installation,  
please contact our Customer Support team at **1.800.897.9755 ext.1**  
or **support@mantelmount.com**. Customer satisfaction is our highest priority!

U.S. Pat. No. 8,864,092 , No. 8,724,037 - For more information on MantelMount patented technology visit: [www.mantelmount.com/pages/patents](http://www.mantelmount.com/pages/patents)

MAILING ADDRESS: 2647 Gateway Road Ste. 105-435 Carlsbad, CA 92009

**mantelmount.com**

© 2021 MANEHU PRODUCT ALLIANCE, LLC

REV. MM720 04-2022