

Step 3: Attach the Adapter Plate to the Display

- a. Attach the Adapter Plate to the display using M4, M5, M6, or M8 screws. For displays with a hole pattern in a pocket or inputs behind Adapter Plate, spacers go between Adapter Plate and display (Fig 3).

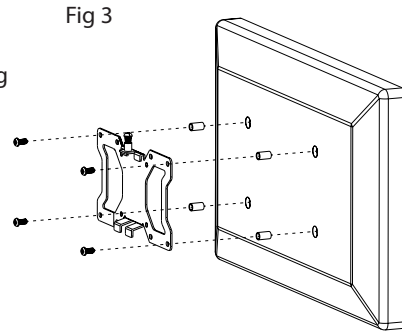

Step 4: Attach the Adapter Plate with Display to Wall Arm Assembly

- a. Attach Adapter Plate and Display onto Wall Arm Assembly, ensuring top and bottom hooks slide into holes of Mounting Head (Fig 4).
- b. Using a long-nosed Philips Head Screwdriver, tighten down Locking Screw located on Adapter Plate into threaded hole in the Mounting Head on Wall Arm Assembly.

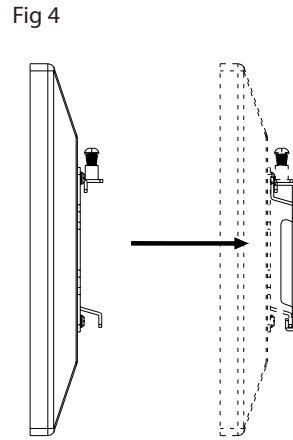
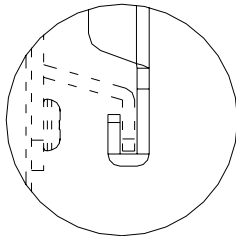

SM-FLAT-S

Strong™ Small Low Profile Flat Mount
(Black)

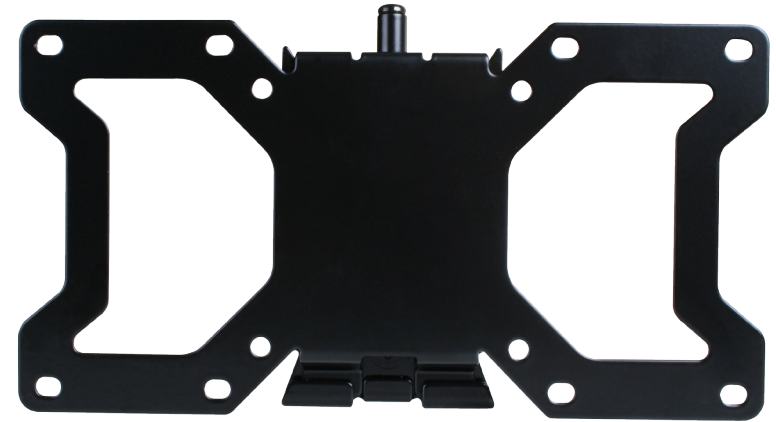

Lifetime Limited Warranty
Strong™ Mounts have a Lifetime Limited Warranty. This warranty includes parts and labor repairs on all components found to be defective in material or workmanship under normal conditions of use. This warranty shall not apply to products which have been abused, modified or disassembled. Products to be repaired under this warranty must be returned to SnapAV or a designated service center with prior notification and an assigned return authorization (RA) number.

For Technical Support call 1.866.838.5052



HARDWARE KIT



M4 x 12mm Philips Head Screw (x4)



Concrete Wall Anchor (x2)



M4 x 20mm Philips Head Screw (x4)



#14 x 2.5" Lag Screw (x2)

WARNINGS

- We highly recommend this product be installed by a qualified professional.
- Please do not begin installation until you have thoroughly read and understood these instructions.
- This mount supports display mounting from VESA 75X75, 100x100 & up to 200x100 and supports a maximum load of 40 lbs (18.2 kg).
- Ensure the wall that you plan to use will safely support four times the combined weight of the mount and your chosen display.
- The manufacturer does not accept responsibility for incorrect installation.

SPECIFICATIONS

- Maximum Load: 40 lbs. (18.2 kg)
- Profile: 3/4"

TOOLS REQUIRED

- Power Drill
- 3/16" (5mm) Drill Bit
- 5/16" (8mm) Masonry Bit
- Phillips Head Screw Driver
- Level

BOX CONTENTS

- Wall Arm Assembly (1)
- Adapter Plate (1)
- Hardware Kit (1)



CAUTION:

This wall mount is intended for use only with the maximum weight of 40 lbs (18.2kg).

INSTALLATION INSTRUCTIONS

Step 1: Use Wall Plate to Mark Mounting Hole Locations

- a. The use of a stud finder is highly recommended.

Step 2: Mount the Wall Arm Assembly

For Mounting on a Stud Wall (Fig 1)

- a. Pre-drill two holes into stud using a 3/16" drill bit. Be sure to drill into the center of the studs.
- b. Insert two Lag Screws into holes through the Wall Plate and tighten down. Be sure the Wall Plate is mounted with the mounting tabs pointing upwards.

WARNING: Tighten screws so that the Wall Plate is firmly attached, but do not over tighten. Over tightening can damage the screws, greatly reducing their holding strength.

Fig 1

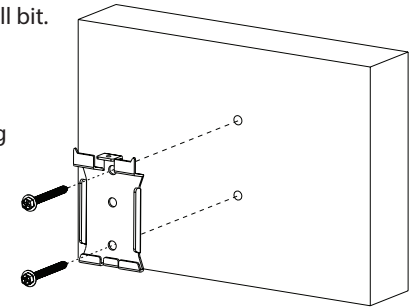

For Mounting on a Concrete Wall (Fig 2)

- a. Pre-drill two holes into concrete using 5/16" drill bits. Insert Concrete Wall Anchors and tap in with hammer, if necessary.

WARNING: When installing Wall Arm Assembly on cinder block, verify first that you have a minimum of 1-3/8" of concrete thickness to be used for the Concrete Wall Anchors. Do not drill into mortar joints! Be sure to mount in a solid part of the block, generally 1" minimum from the side of the block. Cinder block must meet ASTM C-90 specifications. It is suggested that a standard electric drill on slow setting is used to drill the hole instead of a hammer drill to avoid breaking out the back of the hole when entering a void or cavity.

Concrete must be 2000 psi density minimum. Lighter density concrete may not hold concrete anchor.

Make sure that the supporting surface will safely support the combined load of the equipment and all attached hardware and components.

Fig 2

- b. Insert two Lag Screws into the Wall Anchors through the Wall Plate. Be sure the Wall Plate is mounted with the mounting tabs pointing upwards.

WARNING: Tighten screws so that wall plate is firmly attached, but do not over tighten. Over tightening can damage the screws, greatly reducing their holding strength.

