

SM-RAZOR-M/ SM-RAZOR-L

**Strong™ Razor In-Wall
Fixed Mount (Black)**



INSTALLATION MANUAL

WARNINGS:

- Installation by a qualified professional is highly recommended for this product.
- Do not begin installation until you have thoroughly read and understand these instructions.
- Medium mount supports displays from VESA 200X200; 300X300 up to 400X300, and a maximum load of 125 lbs. Large mount supports displays from VESA 200X200; 300X300 up to 800X500, and a maximum load of 125 lbs.
- Ensure the mounting wall will safely support four times the combined weight of the Mount and display panel.
- The manufacturer does not accept responsibility for incorrect installation.
- Due to low profile, check with the TV manufacturer to ensure the particular display being used can be installed 5mm from the wall.

SPECIFICATIONS:

- Maximum Load: 125 lbs. (56 kg)
- Display Size
 - Medium: up to VESA 400X300
 - Large: up to 800X500

BOX CONTENTS:

- Wall Plate (1)
- Arm left (1)
- Arm right (1)

PACKAGE CONTENTS:

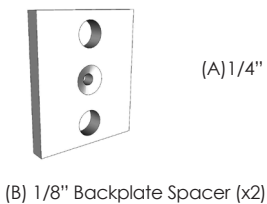
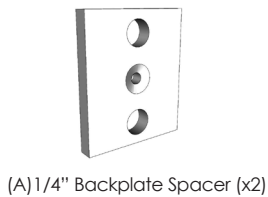
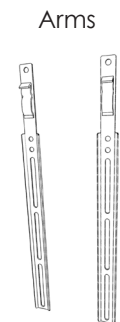
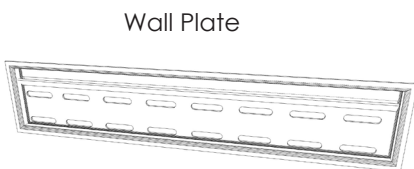

TOOLS REQUIRED:

- Power Drill
- 5/16" and 3/16" Drill Bit
- Phillips Head Screw Driver
- Level
- Drywall Saw
- Stud Finder



CAUTION:

These wall mounts are intended for use only with the maximum weight of :
 SM-RAZOR-M: 125 lbs (56kg)
 SM-RAZOR-L: 125 lbs (56kg)

HARDWARE KIT

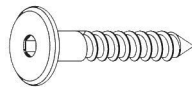

(C) M6x50mm Lag Screws (x4)



(D) Concrete Anchors (x4)

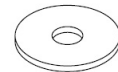

(E) Washers (x4)

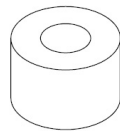

(F) 1/4" ABS Spacer (x4)



(G) M4X12 (x4)

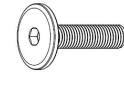

(H) M4X25 (x4)

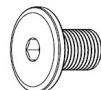

(I) M5X12 (x4)

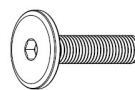

(J) M5X25 (x4)

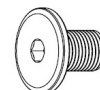

(K) M6X12 (x4)

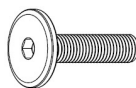

(L) M6X25 (x4)



(M) M8X12 (x4)

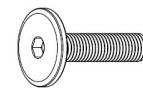

(N) M8X25 (x4)

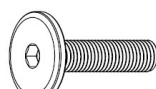

(O) M8X30 (x4)

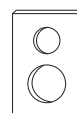

(P) 25mm x 25mm Diameter Washer (x4)



(Q) Allen Key Drill Bit (x1)



(R) M2.5X55mm Allen Key



(S) M4X100mm Allen Key



(T) M5X100mm Allen Key

INSTALLATION:

Note: The SM-RAZOR-M/L mount is designed for in-wall installations when applicable.

Step 1: Mount the Wall Bracket Assembly

For Mounting into a Stud Wall

- Use a stud finder to locate stud positioning for optimal placement. A minimum of two studs are needed.
- Using the Wall Plate, place against the wall face out and trace around the outside of the recess. Remove the Wall Plate and use a dry wall saw to cut and remove the drywall, leaving studs in place.
- First verify fit of Wall Plate into hole without attaching (flanges should cover cuts), then remove.
- Optional next step: Remove backing of Clear Plastic Adhesive Sheet (included) and place over backside of Wall Plate to cover up exposed holes to help eliminate draft from in-wall once mount is installed.
- Pre-drill holes into two wood studs using a 3/16" drill bit. Be sure to drill into the center of the studs at least 2 1/2" deep.
- If drywall is greater than 1/2", determine Spacer needed (either 1/8" or 1/4") to help set depth of Wall Plate flush with drywall. Using a drywall screw, install Spacer (A or B) to stud first through center, tapered hole.
- Insert four Lag Screws (C) into holes through the Wall Plate and tighten down with Allen Key (S).

For Mounting on a Stud Wall

- Pre-drill holes into two wood studs using a 3/16" drill bit. Be sure to drill into the center of the studs at least 2-1/2" deep. The use of a stud finder is highly recommended.
- Insert four Lag screws (C) into holes through the Wall Plate and tighten down with Allen Key (S).

WARNING: Tighten bolts so that wall plate is firmly attached, but do not overtighten. Overtightening can damage the bolts, greatly reducing their holding strength.

For Mounting on a Concrete Wall

- Pre-drill holes into concrete using 5/16" drill bits to a depth of 2 1/2". Insert concrete Wall Anchors (D) and tap in-with hammer, if necessary (Figures 3 & 4).

WARNING: When installing wall arm assembly on cinder block, verify first that you have a minimum of 1-3/8" of concrete thickness to be used for the concrete anchors. Do not drill into mortar joints! Be sure to mount in a solid part of the block, generally 1" minimum from the side of the block. Cinder block must meet ASTM C-90 specifications. It is suggested that a standard electric drill on slow setting is used to drill the hole instead of a hammer drill to avoid breaking out the back of the hole when entering a void or cavity.

Concrete must be 2000 psi density minimum. Lighter density concrete may not hold anchors.

Make sure that the supporting surface will safely support the combined load of the equipment and all attached hardware and components.

Figure 1

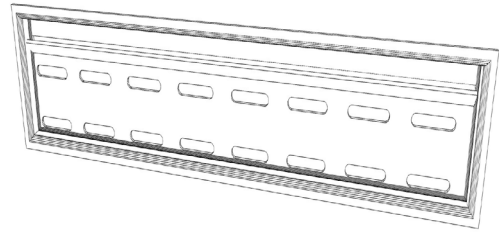
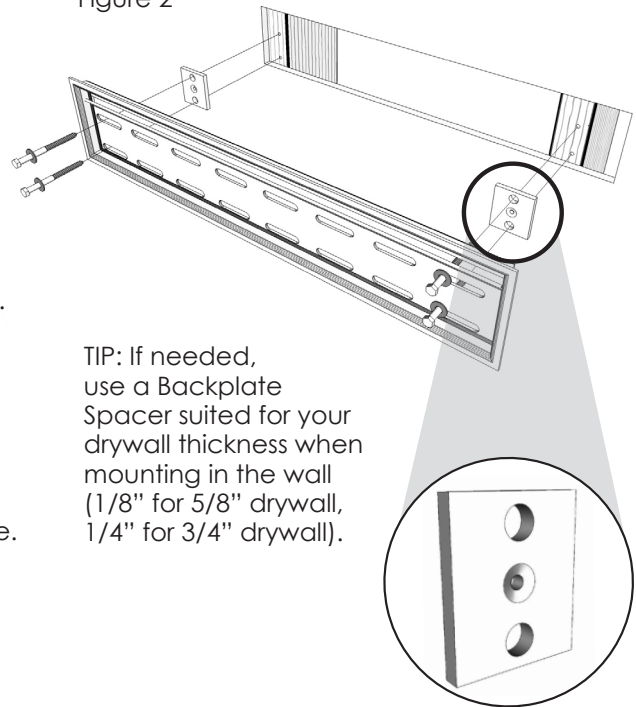

Figure 2



TIP: If needed, use a Backplate Spacer suited for your drywall thickness when mounting in the wall (1/8" for 5/8" drywall, 1/4" for 3/4" drywall).

Figure 3

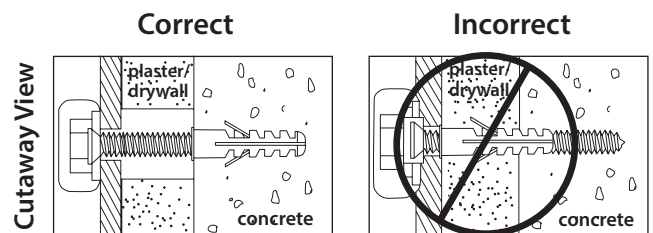
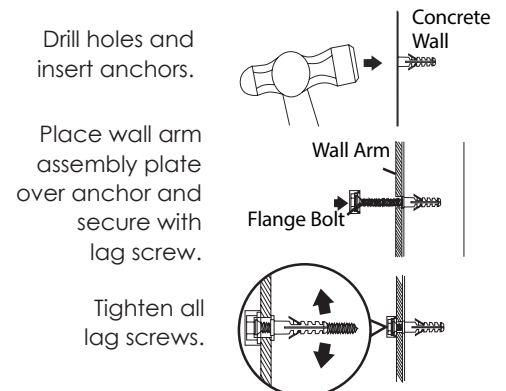

Figure 4



- b. Insert four Lag Screws (C) into the Wall Anchors through the Wall Plate. Tighten all bolts with Allen Key (S).

WARNING: Tighten bolts so that wall plate is firmly attached, but do not overtighten. Overtightening can damage the bolts, greatly reducing their holding strength.

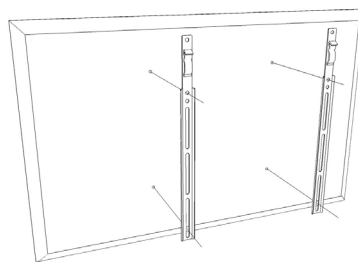

Figure 5

Step 2: Mount Arms to TV

- a. Determine the diameter of the screw (parts G through O) your TV requires by carefully trying to hand-thread one into the threaded insert on the rear of the TV. If there is any resistance, stop immediately.
- b. Spacers are commonly needed on TVs with curved backs or recessed screw inserts. The screw will thread through the appropriate washer (P), any spacer needed (F) and the arms into the TV.
- c. Ensure the arms are installed flat side to TV and are square to each other after all screws have been installed (Figure 5).

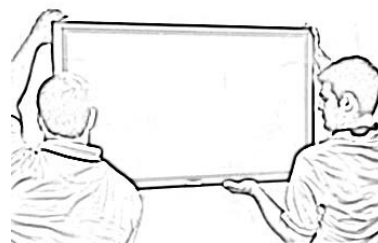

Figure 6

Step 3: Hang TV on to the Wall Plate

- a. Carefully lift the TV and place arm hooks over and onto angled lip in Wall Plate (Figure 7). Do not release the TV until it is completely connected to the Wall Plate.

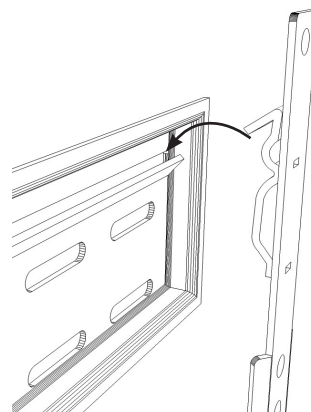

Figure 7



Lifetime Limited Warranty

Strong™ Mounts have a Lifetime Limited Warranty. This warranty includes parts and labor repairs on all components found to be defective in material or workmanship under normal conditions of use. This warranty shall not apply to products which have been abused, modified or disassembled. Products to be repaired under this warranty must be returned to SnapAV or a designated service center with prior notification and an assigned return authorization (RA) number.

For Technical Support call 1.866.838.5052