

WATT BOX™

WB-250-IPW-2

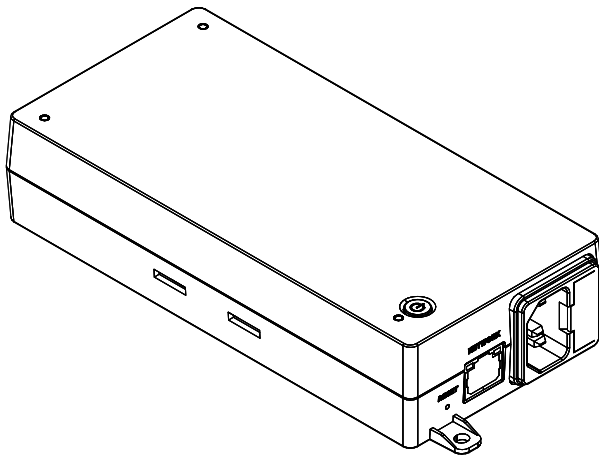

QUICK START GUIDE

ANATOMY

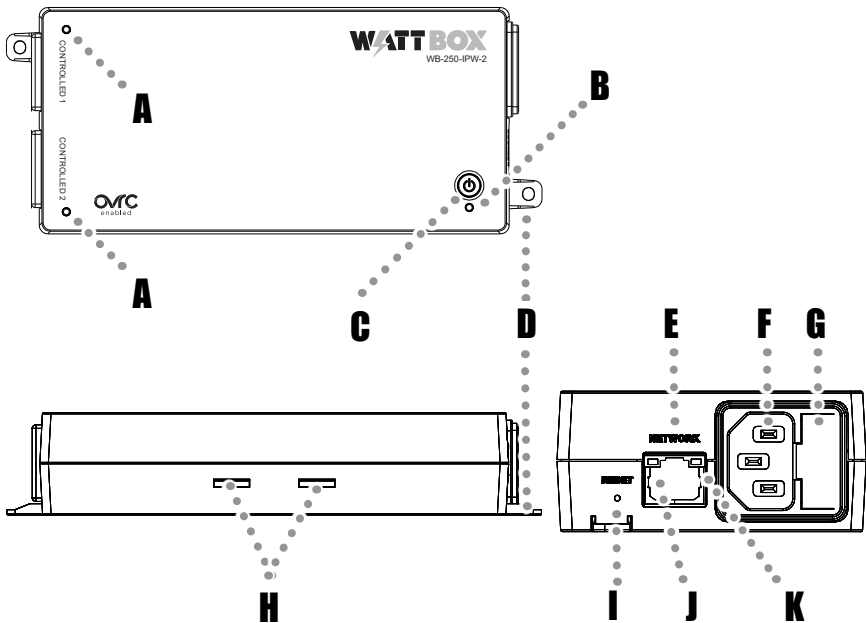

- A. Outlet LEDs: These illuminate when power to the matching outlet is on. The outlets are switchable (IP controlled).
- B. Power/Network LED: See page 4.
- C. AC Power Button: Press to manually toggle the outlets on or off.
- D. Mounting Eyelets.
- E. Network Connection: Connect to the Local Area Network (LAN) for IP setup, control, and monitoring.
- F. Power Inlet: Outlet for 3-prong IEC power cord.
- G. External Fuse*: May need replacement after an overload.
- H. Mounting Bracket Grooves
- I. Reset Button: Use a thin tool (paper clip, toothpick) to press this to restart the network card (no settings are changed). Press and hold 5 seconds to set the power strip to DHCP. Press and hold 10 seconds to reset the power strip to factory default.
- J. Internet LED: See page 4.
- K. Link/Activity LED: See page 4.

* **CAUTION:** For inlet fuse rating: T15AH, 125VAC/250VAC or F15AH, 125VAC/250VAC. Failure to replace the fuse with the same size, type, and ratings will damage the device and the connected and nearby equipment, and will cause electrical shock, fire, explosion, or injury.

LED INDICATORS

Link/ Activity LED	Flickering Green: Send/Receive Activity. Off: No data is passing.
Internet LED	Solid Green: All host pings successful. Blinking Green: At least one host ping successful. Off: All host pings timed out.
Power/ Network	Solid Amber: Unit has AC power, and a wired network connection. Solid Green: Unit has AC power, and Wi-Fi is connected. Blinking Amber: Unit has AC power, and is searching for Wi-Fi. Off: No AC power.
Outlet LEDs	Solid Green: Outlets ON. Off: Outlets OFF. Note: Each outlets is controllable.

PACKAGE CONTENTS

This package contains:

- The WattBox 250 Series Power Strip
- Removable IEC power cord
- 2 wall anchors with M3×16mm screws

MOUNTING INSTRUCTIONS

This unit can be mounted on any flat surface, either vertically or horizontally.

Use the screws and anchors provided to install the unit on a wall as pictured to the right.

Use double-sided tape or hook and loop closures (not provided) to attach the unit to a flat surface.

An optional mounting bracket is available as a separate accessory.

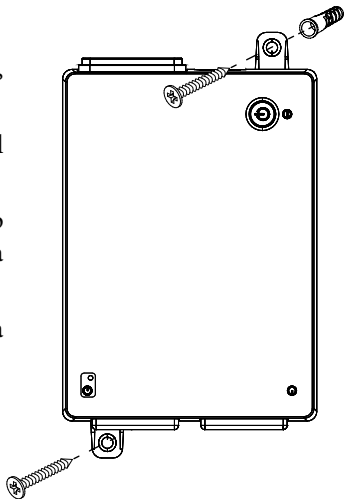

CONNECTION DIAGRAM

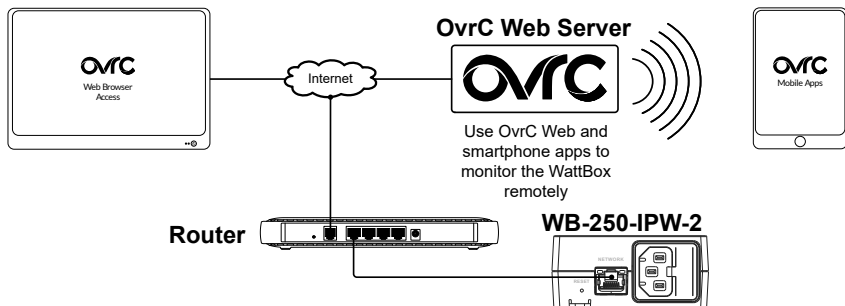

INSTALLATION

NOTE: This device **always** connects via the wired connection while it is physically connected to an active network switch port. The Wi-Fi capabilities are only activated when the device is **not hardwired** to a network.

1. Ensure the WB-250 is connected by ethernet cable to the internet.
2. Check the IP address of the WB-250 using an IP scanner or the router's client table. **If your WB-250 will remain hardwired, skip to step 7 now.**

Optional Steps for Wireless Operation

3. Navigate to the IP address of the WB-250, and log in to its local interface.
4. In the interface, navigate to **Configure > Wireless IP Settings**. Press the **Scan** button.
5. Locate the SSID for your WAP or router. Select that SSID and log in to that wireless network.
6. Disconnect the Ethernet cable (otherwise the WB-250 continues to operate in wired mode). After a few minutes, the power LED turns from orange to green, indicating that the unit is now operating wirelessly.

Finishing the Install

7. Log in to your OvrC account.
8. Add the WB-250 using its MAC address and service tag (ST) number.

You can now complete setup through OvrC. Ensure your firmware is up to date, schedule automatic reboots, and set up boot delays.

TROUBLESHOOTING

Symptom	Possible Cause	Remedy
A device won't power up when the WattBox is turned on.	The WB outlet is switched off.	Log in to the WattBox interface to turn the outlet on.
	The device is not turned on.	Turn the device's power switch on.
WattBox is not receiving power (the LED does not illuminate 1 minute after connecting AC power).	WattBox is not turned on.	If the power button does not glow, press it.
	No power is being supplied.	Ensure the WattBox is plugged into a properly grounded 120V outlet. Check the outlet's switches and circuit breakers.
	Too many devices are connected.	Check the fuse on the AC Inlet. If it is blown, reduce the load and replace fuse.
	Surge protection has been consumed during a surge event.	The unit needs to be replaced.
Speakers emit a humming or buzzing noise.	WattBox is sharing power with gear that is not properly grounded.	Connect WattBox to a dedicated outlet. Unplug components one at a time to see if the noise stops.

IMPORTANT SAFETY INSTRUCTIONS

Read and observe the following safety points at all times.

NOTICE

For indoor use only. Internal components are not sealed from the environment. The device can only be used in a fixed location. When you install the device, ensure that the protective earthing connection of the socket-outlet is verified by a skilled person. Suitable for installation in Information Technology Rooms in accordance with Article 645 of the National Electrical Code and NFPA 75.

Only use brackets/attachments/accessories specified by the manufacturer.

Do not place the device in an unstable position where it might fall and cause injuries. This equipment is not suitable for use in locations where children are likely to be present.

Do not cover this device with a cloth. Do not install it on a carpet or rug.

CAUTION – Potential Injury

Do not use this product with extension cords, multioutlet power strips, multioutlet extenders, or UPS devices (other than a WattBox UPS). The power capacity of these accessories can be overloaded by this product and may result in a risk of fire, or property damage.

WARNING – Power Sources, Grounding, Polarization

This plug is designed to be inserted into a NEMA 5-15 (three-prong grounded) outlet only. Do not force the plug into an outlet that is not designed to accept it. Never dismantle the plug or to alter the power cord, and do not attempt to defeat the grounding feature by using a 3-to-2 prong adapter. If you have questions about grounding, consult your local power company or a qualified electrician.

This WattBox requires a properly grounded outlet for safety. If you're not sure if your home's electrical wiring is properly grounded, have it checked by a qualified electrician.

If a rooftop devices such as a satellite dish connects to the WattBox, ensure that the device's wires are also properly grounded.

WARNING – Liquid: Avoiding Electrical Shocks

Do not operate the WattBox if liquid of any kind is spilled onto or inside the unit. Do not operate it near rain or water, even water that is contained (e.g., bathtub or sink).

WARNING – Power Cord Safety

Do not place the power cord near areas with heavy foot traffic (e.g., hallways). Do not create a trip hazard with the power cord.

If the power cord's protective jacket rips or frays, exposing the internal wiring or shielding, disconnect it from the power source and replace the power cord immediately. See the warranty section of the owner's manual for details.

WARNING – No User Serviceable Parts Inside

If the WattBox is not operating properly, do not remove any part of the unit (cover, etc.) for repair. Unplug the unit and consult the warranty section of the owner's manual.

CAUTION – Exposure to Heat

Do not expose the WattBox to direct sunlight or place it near wall heaters, space heaters, or in an enclosed space prone to temperature increase.

Do not use the device in a confined, poorly-ventilated location; this can overheat the unit, possibly even causing a fire. If used in a small space other than an EIA-standard rack, ensure that there is adequate space around the device.

CAUTION – Proper Cleaning

In general, the only cleaning necessary for is a light dusting. Unplug WattBox from the wall outlet before cleaning it. Do not use liquid or aerosol cleaners.

FEDERAL COMMUNICATION COMMISSION INTERFERENCE STATEMENT

This equipment has been tested and found to comply with the limits for a Class B digital device, pursuant to Part 15 of the FCC Rules. These limits are designed to provide reasonable protection against harmful interference in a residential installation. This equipment generates, uses, and can radiate radio frequency energy and, if not installed and used in accordance with the instructions, may cause harmful interference to radio communications. However, there is no guarantee that interference will not occur in a particular installation. If this equipment does cause harmful interference to radio or television reception, which can be determined by turning the equipment off and on, the user is encouraged to try to correct the interference by one or more of the following:

- Reorient or relocate the receiving antenna.
- Increase the separation between the equipment and receiver.
- Connect the equipment into an outlet on a circuit different from that to which the receiver is connected.
- Consult the dealer or an experienced radio/TV technician for help.

FCC Radiation Exposure Statement:

This equipment complies with FCC radiation exposure limits set forth for an uncontrolled environment. This equipment should be installed and operated with minimum distance 20cm between the radiator & your body.

INDUSTRY CANADA STATEMENT

This device complies with ISED's license-exempt RSS standard(s). Operation is subject to the following two conditions: (1) this device may not cause interference, and (2) this device must accept any interference, including interference that may cause undesired operation of the device.

Le présent appareil est conforme aux CNR d'ISED applicables aux appareils radio exempts de licence. L'exploitation est autorisée aux deux conditions suivantes : (1) l'appareil ne doit pas produire de brouillage, et (2) l'utilisateur de l'appareil doit accepter tout brouillage radioélectrique subi, même si le brouillage est susceptible d'en compromettre le fonctionnement.

Radiation Exposure Statement:

This equipment complies with IC radiation exposure limits set forth for an uncontrolled environment. This equipment should be installed and operated with minimum distance of 20 cm between the radiator and people and animals.

Déclaration d'exposition aux radiations:

Cet équipement est conforme aux limites d'exposition aux rayonnements IC établies pour un environnement non contrôlé. Cet équipement doit être installé et utilisé avec un minimum de 20 cm de distance entre la source de rayonnement et des personnes ou des animaux.

WARRANTY

2-Year Limited Warranty

This SnapAV® product has a 2-Year Limited Product Warranty. This warranty includes parts and labor repairs on all components found to be defective in material or workmanship under normal conditions of use. This warranty shall not apply to products which have been abused, modified, or disassembled. Products to be repaired or replaced under this warranty must be returned to SnapAV or a designated service center with prior notification and an assigned return authorization number (RA). Contact technical support for an RA number.

Once you obtain an RA number, please mark the number on the bottom of the unit and pack it in a shipping carton/box with enough packing material to protect it during transit. The RA number must also be clearly marked on the outside of the carton. Ship the unit to SnapAV. Please note that you are responsible for any and all charges related to shipping the unit to SnapAV.

WARRANTY LIMITATION:

SnapAV products not purchased directly from SnapAV or authorized SnapAV dealers or authorized distributors are excluded from above warranties.



WARNING: This product can expose you to chemicals including lead, which is known to the State of California to cause cancer and reproductive harm. For more information go to www.P65Warnings.ca.gov.



Retain this label for your records

LOGGING IN TO THE WEB INTERFACE

You need to enter the username and password to access the web interface. The default entries are below; change these to maintain proper security (and log them below).

Username default: *wattbox* New Username: _____

Password default: *wattbox* New Password: _____

WATT BOX

engineered by
Snap