

See Specifications for Individual Amounts

## KEY FEATURES

**Surge Protection with Fireproof MOVs** - Advanced Ceramic MOV technology reduces risk of fire from surges.

**Surge Disconnect** - In the event of a catastrophic surge event, this Wattbox™ component will sacrifice itself and permanently disconnect AC power.

**Noise Filtration** - Eliminates AC noise to improve picture and sound quality.

**Flexible Power Cord** - Wattbox™ power cords are both flexible and durable and designed for ease of installation.

**Secondary Protection** - Protected 3 GHz signal coax/satellite connections plus Ethernet / Telephone connections.

**Flexible Mounting** - Wattbox™ flexible mounting options allows vertical, horizontal or angled mounting. Mounts flush with back of the rack and allows the installer to easily reach outlets. Hardware is included to mount to the wall or back of a cabinet. See Mounting Options on Pg. 4.

**IP Control** - Provides control of outlets over an IP network. Cycle outlet state, turn outlets On or Off through a web browser.

**Auto Reboot** - Monitors network activity and resets power to outlets when programmable conditions are met.

**Outlet Control Scheduling** - Configure outlets to turn Off or On at a specific date or time.

**System Notifications** - Programmable email notifications keep you informed of System Status Changes.

## WELCOME TO WATTBOX™

WattBox™ power products are designed specifically to provide customers with advanced protection for their valuable electronics, and Custom Integrators with maximum flexibility for installation. With this IP-enabled power conditioner, both service calls and system downtime are reduced, and the self-healing Auto Reboot feature automatically resets components that become unresponsive on the network. Plus, you get a host of remote access features to monitor and control individual outlets – even receive email notifications that keep you informed about the system's status.

Rest assured that WattBox™ products will deliver the protection and safety for your customers' needs. All WattBox™ products are UL certified and built with the highest quality components available, such as Fireproof MOVs. Whether in a rack, a structured wiring enclosure, or behind a flat screen, the versatile mounting options offer simple installation of WattBox™ for easily managing power cords, adapters and signal cables.

WattBox™ is the ideal choice for Custom Integrators who demand reliability, safety, and flexibility when installing power products for their valued customers.

## PACKAGE CONTENTS



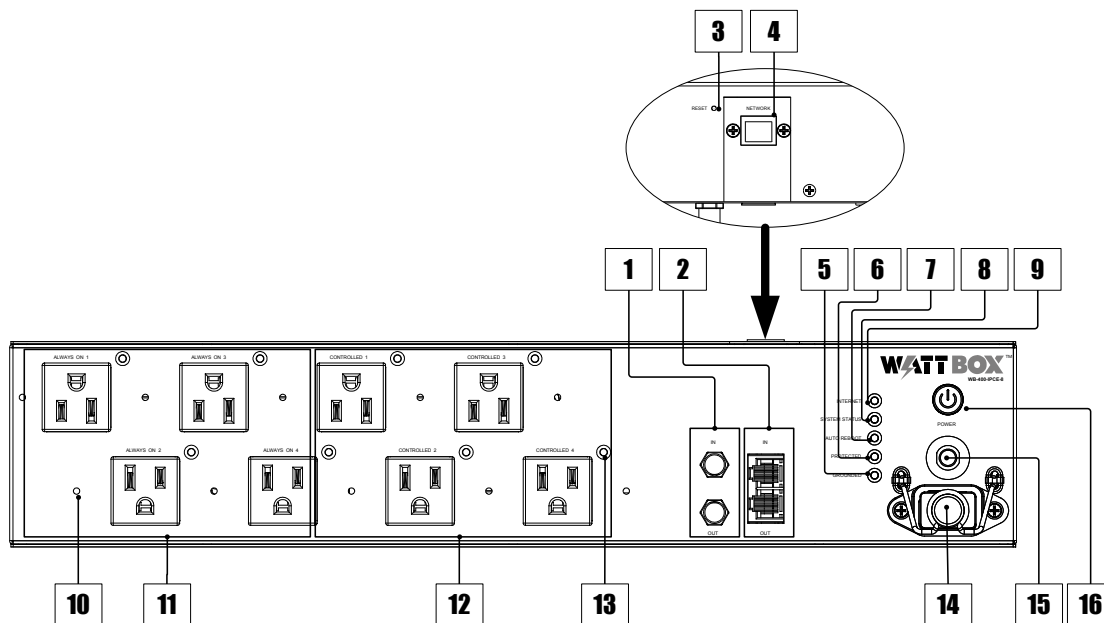

- |                    |  |
|--------------------|--|
| (1) WB-400-IPCE-8  | (4) Rubber Feet  |
| (1) 6ft Power Cord | (2) Sheets of Power Cord Labels (16 total labels)                      |
| (2) Small Brackets | (1) Owner's Manual   |
| (2) Large Brackets | (1) DVD Rom Containing Support Documents and WattBox™ Utility Software |
| (8) Bracket Screws | (4) Washers, Screws, and Anchors                                       |
|                    | (6) Power Adapter Hook & Loop Tie Down Straps                          |

## REAR PANEL



1. Protected 3GHz coax connections for cable/satellite
2. Protected connections for Ethernet / Telephone (Not for IP Control)
3. Network Connection Reset Button
4. RJ45 Network Connection (For IP Control)
5. Ground indicator LED
6. Surge Protection indicator LED
7. Auto Reboot Enabled Indicator LED
8. System Status Indicator LED
9. Internet Activity Indicator LED
10. Hook & Loop Strap Lockdown – See Securing Power Adapters on Pg. 5
11. Outlets 1 – 4 – Always On
12. Outlets 5 -8 –Controlled via IP Interface
13. Power Indicators for Outlets 1-8 – Illuminates when power is ON (x8 – 1 for each outlet)
14. Detachable power cord outlet with locking clip
15. 15 Amp resettable circuit breaker
16. AC Power switch

## LED OPERATION

INTERNET		Green (Solid):	All sites/IP Addresses are communicating with the WattBox
		Green (Flashing):	At least 1 (not all) Sites/IP Addresses are communicating with the WattBox
		Red (Solid):	None of the Sites/IP Addresses are communicating with the WattBox.
SYSTEM STATUS		Green (Solid):	WattBox processor is in an operating state and can be accessed via the WattBox interface
		Green (Flashing):	Firmware for the WattBox processor is being updated, during this state the WattBox cannot be accessed via the WattBox interface.
		Red (Solid):	WattBox processor is NOT in an operating state, reset button must be pressed to return the WattBox to an operating state.
AUTO REBOOT		When Illuminated:	Auto Reboot is Enabled, WattBox will perform power cycle for outlets that are ON when communication with the assigned Website/IP Address is lost. Note that outlets that are OFF, will not power cycle.
		When Not Illuminated:	Auto Reboot is Disabled, no power cycle will occur when communication with the assigned Website/IP Address is lost.
PROTECTED		Green (Solid):	The WattBox is powered on and outlets are protected.
		Off:	The WattBox is not powered on, or the MOVs have opened removing power from the outlets.
GROUNDED		Green (Solid):	Incoming AC outlet is grounded.
		Off:	Incoming AC outlet is not grounded and requires inspection by an electrician.

# MOUNTING OPTIONS

The Wattbox™ 400 Series is designed for standard 19" equipment racks and features versatile mounting options. The multi-position bracket allows vertical, horizontal or angled mounting. The unit can also be mounted flush with the rack or set back to the most convenient position for a particular installation.

Attach the brackets to the Wattbox™ in the position desired. Install the Wattbox™ using supplied hardware.

## Small Bracket Mounting

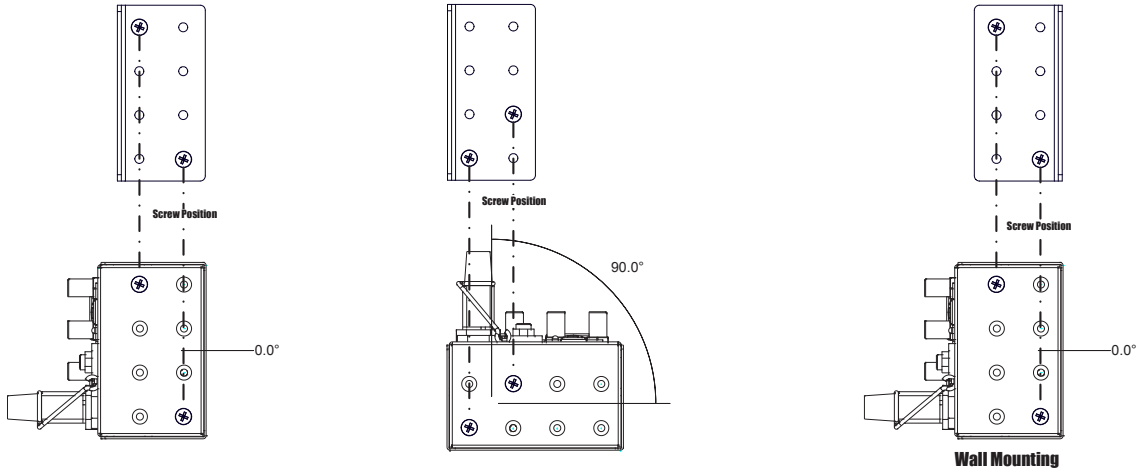

## Large Bracket Options

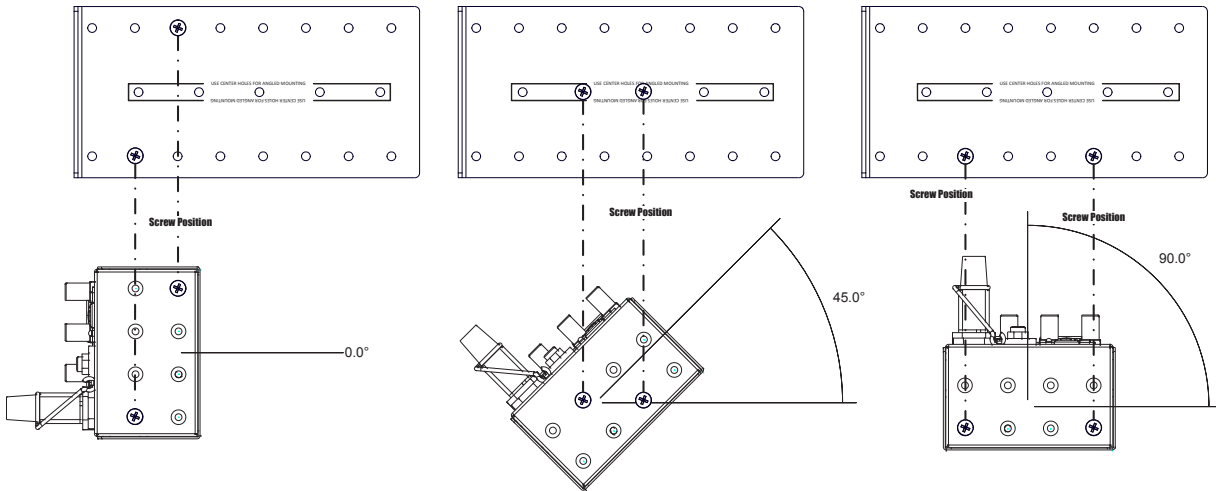

## WALL MOUNTING

The WB-400 series can be mounted to a wall or cabinet by using the small bracket. Mount the small bracket to the WB-400 with the flat part of the bracket facing away from the outlets.

1. Locate wall studs using a stud finder (not included).
2. Position the provided template on the wall in the desired location of the Wattbox™. If the location does not allow for this, use a wall molly or anchor with the appropriate weight rating for the Wattbox™.

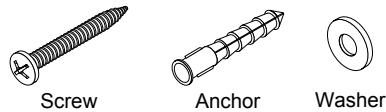

3. Level the template and mark the wall with the screw locations.

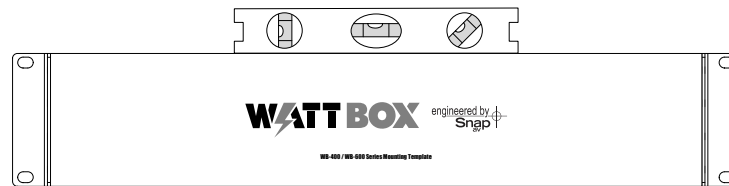

4. Secure the Wattbox™ to the wall.

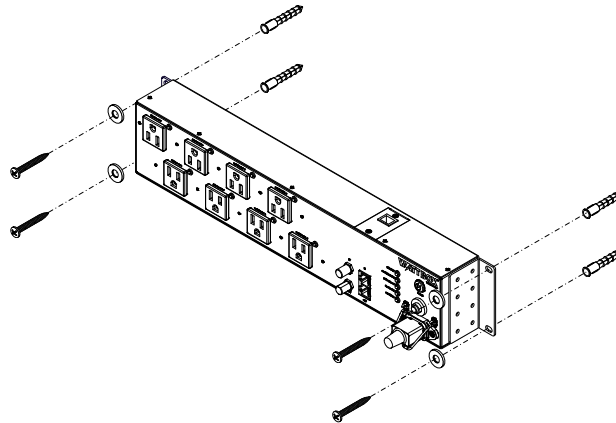

## SECURING POWER ADAPTERS

The Wattbox™ 400 series is supplied with Hook & Loop straps that can be used to secure power adapters to the outlets.

1. Remove the screw on both sides of the outlet.
2. Insert the screw in the eyelet on the Hook & Loop straps.
3. Tighten the screw to secure the strap.
4. Wrap the Hook & Loop straps over the power adapter and tighten.

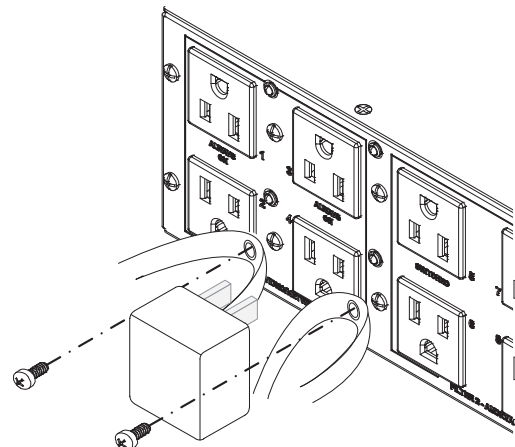

## IP CONNECTIONS

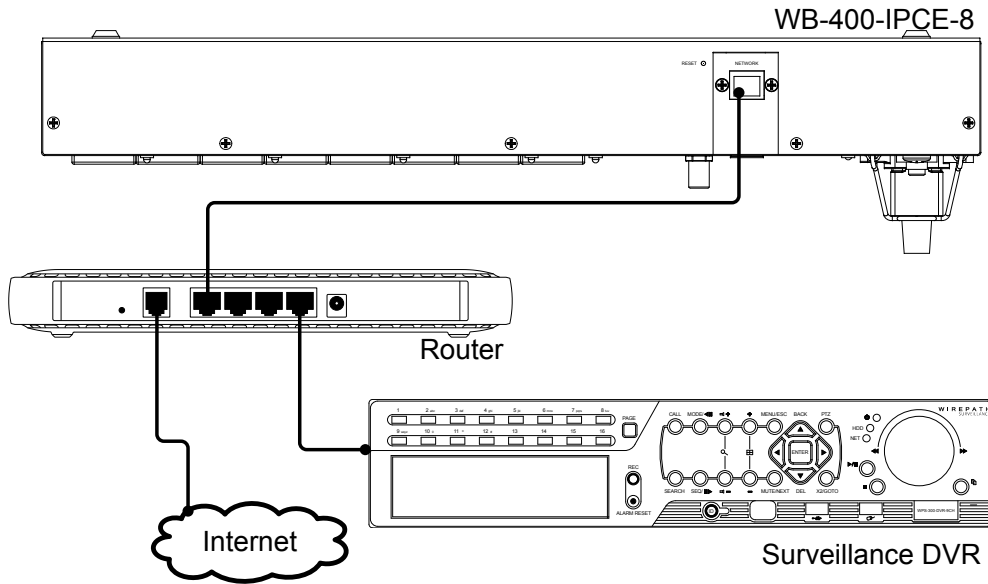

After connecting the WB-400-IPCE-8 to the network, configuration for IP control is performed using the Wattbox Utility. The utility and documentation on configuring the Wattbox can be found on the included CD Rom and the SnapAV website ([www.snapav.com](http://www.snapav.com)).

**Note: WattBox™ must be connected to the network and the router on before applying power to the WattBox™.**

## IMPORTANT SAFETY INSTRUCTIONS

Read and observe the following safety points at all times.

### **WARNING – Power Sources**

Do not plug this Component into a power outlet that differs from the source indicated for safe use on the Component. If you don't know the type of electrical power that is supplied to your home, consult your local power company or a qualified electrician.

### **WARNING – Grounding and Polarization**

This plug is designed to be inserted into a grounded-type outlet only. Do not force the Component plug into an outlet that is not designed to accept a three-wire grounded-type AC plus (three prong plug) Never attempt to dismantle the plug in any way (or to alter the powercord), and do not attempt to defeat the grounding feature by using a 3-to-2 prong adapter. If you have questions about grounding, consult your local power company or a qualified electrician.

This Wattbox™ component requires a properly grounded outlet for safety and to protect connected equipment. If you're not sure if your home's electrical wiring is properly grounded, have it checked by a qualified electrician.

If any rooftop devices such as satellite dishes, antennas, or any other component with wire being used that connects to the Component, be sure the wire(s) is properly grounded. This protects against voltage surges and static charges.

Do not place any antenna near overhead power lines or any other power circuit. Do not touch any power line or power circuit. Doing so may cause severe physical injury or possibly death.

### **WARNING – Liquid: Avoiding Electrical Shocks**

Do not operate the Component if liquid of any kind is spilled onto or inside the unit. Do not operate the Component near rain or water that's spilled or contained (e.g., bathtub, kitchen or sink).

### **WARNING – Power Cord Safety**

When routing the Component's AC power cord, do not place it near heavy foot traffic areas (e.g. sink or bathtub).

If the power cord's protective jacket begins to rip or fray, exposing the internal wiring, shielding, etc., disconnect it from the AC power source and discontinue use of the Component immediately. See the Warranty Information section of this owner's manual for important details.

### **WARNING – No User Serviceable Parts Inside**

If, for any reason, the Component is not operating properly, do not remove any part of the unit (cover, etc.) for repair. Unplug the unit and consult the Warranty Information section of this owner's manual for important details.

### **CAUTION – Exposure To Heat**

Do not expose the Component to direct sunlight or place it near wall heaters, space heaters, or any enclosed space prone to temperature increase.

### **CAUTION – Proper Cleaning**

In general, the only cleaning necessary for the Component is a light dusting. Unplug the Component from the wall outlet before cleaning it. Do not use any type of liquid or aerosol cleaners.

### **CAUTION – Earthing**

Component should be installed by certified service personnel to ensure that the product is connected to a socket-outlet with a protective earthing connection.

Symptom	Possible Cause	Remedy
Wattbox™ is not receiving power. <b>TROUBLESHOOTING</b>	Wattbox™ is not turned On.	<ul style="list-style-type: none"> <li>Turn Wattbox™ switch on. Make sure AC power plug is plugged into a properly grounded 120 volts (nominal) wall outlet.</li> <li>In some households, a wall switch may need to be turned on to make the wall outlet active. Try turning on the light switches located near the wall outlet.</li> </ul>
	Too many devices are connected, causing an overload, tripping the Thermal Circuit Breaker.	<ul style="list-style-type: none"> <li>Press Wattbox™ resettable circuit breaker button in to reset. Please allow 10 minutes before attempting to reset. If reset too soon, the breaker will prematurely sense power overload and not allow Wattbox™ to operate.</li> <li>If the circuit breaker continues to trip, try moving one or more components to another Wattbox™. Too much current may be drawing through one Wattbox™.</li> </ul>
Component is not receiving power.	Component is plugged into a controlled outlet and the outlet is off.	<ul style="list-style-type: none"> <li>Log into WattBox interface to turn the outlet On</li> </ul>
	Component is plugged into a controlled outlet, but power on the component is not On. In some instances, a component plugged into a switched outlet won't receive power when Wattbox™ is turned On unless the component power is also switched On.	<ul style="list-style-type: none"> <li>Turn the component power On.</li> </ul>
Speakers emit a humming or buzzing noise.	Wattbox™ is sharing AC power with equipment that is not properly grounded.	<ul style="list-style-type: none"> <li>Connect Wattbox™ to a dedicated outlet.</li> <li>Try unplugging different components from Wattbox™ one at a time to see if the noise stops.</li> </ul>



## SPECIFICATIONS

<b>AC Power</b>	
Line Voltage	120V, 60Hz
AC Input Connection	IEC C-14
Power Cord Length	6 Feet
Circuit Breaker Rating	15A
UL Current Rating	12A
Voltage Protection Rating (UL 1449 3rd Edition)	500V
Joule Rating	3240 Joules
Surge Component	Ceramic Encased MOV
Protection Modes	L-N, L-G, N-G
Peak Impulse Current	72,000A
Disconnect Circuitry	Yes
Thermal Fuse	Yes
<b>Outlets</b>	
Type	NEMA 5-15
Number of Outlets	8
IP Controlled	4
<b>EMI / RFI Noise Filtration</b>	
All Outlets	53 dB, 1kHz to 1MHz
<b>Cable / Satellite Circuit</b>	
Connections	Gold Plated "F" Connector
Surge Component	Gas Tube
Clamping Voltage	600V
Frequency Range	0MHz - 3.0 GHz
Insertion Loss	< 0.5 dB
Shielded	Yes
Bi-directional	Yes
<b>Phone / LAN Circuit</b>	
Jacks	RJ45
Accepts	RJ11 & RJ45
Surge Component	Sidactor & MOV
Clamping Voltage	RJ11:400V; RJ45:250V
Wires Protected	8 Wires
<b>UL Certifications</b>	
UL 60950-1, UL 1449, UL 498, UL 1283	
<b>Dimensions</b>	
3.47" H x 17.02" W x 2.13" D	
<b>Connected Equipment Warranty</b>	
\$50,000	

## WARRANTY

### SnapAV Surge Protector Lifetime Product Warranty

SnapAV warrants to the purchaser of any standard SnapAV surge protector that the surge protector shall be free of defects in design, material, or workmanship, and SnapAV will repair or replace any defective unit. For product replacement, see "NOTIFICATION" below.

### Lifetime Replacement Policy

Valid only in the United States and Canada. If your SnapAV surge protector becomes damaged while protecting your connected equipment, you may request an equivalent replacement to the latest technology of that product category. Keep a copy of the original invoice to verify the product belongs to the original purchaser.

### Warning Notice

### WARRANTY LIMITATION FOR INTERNET PURCHASERS:

SnapAV products purchased outside of the SnapAV internet website do not carry a valid Connected Equipment Protection Policy unless purchased from an Authorized SnapAV Dealer.

**CAUTION:** Audio/Video, computer and/or telephone system installations can be very complex systems, which consist of many interconnected components. Due to the nature of electricity and surges, a single protector may not be able to completely protect complex installations. In those cases, a systemic approach using multiple protectors must be employed. Systemic protection requires professional design. AC power, satellite cables, CATV cables, or telephone/network lines entering the system that do not pass through this surge protector will render the SnapAV connected equipment protection policy null and void. For additional information on how to protect your system, please contact SnapAV before connecting your equipment to the surge protector.

### SnapAV Surge Protector Connected Equipment Protection Policy

Valid only in the United States and Canada. It is the policy of SnapAV that it will, in its sole discretion, replace, pay to replace at fair market value, or pay to repair, up to the dollar amount specified below, equipment that is damaged by an AC power, cable, telephone, or lightning surge while connected to a properly installed SnapAV surge protector. SnapAV must determine that the surge protector shows signs of surge damage or is operating outside of design specifications, relative to its surge protection capability, and under all of the circumstances failed to protect your connected equipment.

### THIS POLICY IS SUBJECT TO THE CONDITIONS BELOW:

#### 1. PROOF OF PURCHASE REQUIRED:

SnapAV's connected equipment policy extends to the original purchaser of the SnapAV product only and is non-transferable. Original purchase receipts must accompany any product return or claim for connected equipment damage.

#### 2. PROPER INSTALLATION:

SnapAV AC protectors must be directly plugged into a properly grounded 3-wire AC outlet. Extension cords, non-grounded two prong adapters, or other non-SnapAV surge products must not be used. Building wiring and other connections to protected equipment must conform to applicable codes (NEC or CEC). No other ground wires or ground connections may be used. All wires (ie.g., AC power lines, telephone lines, signal/data lines, coaxial cable, etc.) leading into the protected equipment must first pass through a single Sna AV protector designed for the particular application. The protector and the equipment to be protected must be indoors in a dry location, and in the same building. SnapAV installation instructions and diagrams must be followed.

#### 3. NOTIFICATION:

You must notify SnapAV within fourteen days of any event precipitating a request for product replacement or payment for connected equipment damage. A return authorization (RA) number must first be obtained from the SnapAV Customer Service Department at [www.snapav.com/support](http://www.snapav.com/support) before returning the protector to SnapAV. At this time, you must notify SnapAV if you believe you have a claim for damaged connected equipment.

Once you obtain a RA number, please mark the number on the bottom of the unit and pack it in a shipping carton/box with enough packing material to protect it during transit. The RA number must also be clearly marked on the outside of the carton. Ship the unit to SnapAV. Please note that you are responsible for any and all charges related to shipping the unit to SnapAV.

If connected equipment damage was indicated on your RA request, SnapAV will request the make and model of all connected equipment, a connection diagram of your system, as well as other requests based on the extent of the request for product placement or payment for connected equipment damage. All requests by SnapAV are to be completed and returned within 30 days. Be sure to note its configuration before disconnecting your equipment.

#### **4. DETERMINATION OF FAILURE:**

SnapAV will evaluate the protector for surge damage. The protector must show signs of surge damage or must be performing outside of design specifications relative to its surge protection capability. Opening the enclosure, tampering with, or modifying the unit in any way shall be grounds for an automatic denial of your request for payment. SnapAV, after evaluating all information provided, shall, in its sole discretion, determine whether or not your request is eligible for payment.

If the surge protector shows no signs of AC power or signal line surge damage and is working within design specifications, SnapAV will return the unit to you explaining the test results and notifying you of the rejection of your claim. SnapAV reserves the right to inspect the damaged connected equipment, parts, or circuit boards. SnapAV also reserves the right to inspect the customer's facility. Damaged equipment deemed uneconomical to repair must remain available for inspection by SnapAV until the claim is finalized.

#### **5. REQUEST PAYMENTS:**

Once SnapAV has determined that you are entitled to compensation, SnapAV will, at its election, pay you the present fair market value of the damaged equipment, or pay for the cost of the repair, or send you replacement equipment, or pay the equivalence of replacement equipment.

#### **6. OTHER INSURANCE/WARRANTIES:**

This coverage is secondary to any existing manufacturer's warranty, implied or expressed, or any insurance and/or service contract that may cover the loss.

#### **7. EXCLUSIONS:**

THE SNAPAV SURGE PROTECTOR EQUIPMENT POLICY DOES NOT APPLY TO: Service charges, installation costs, reinstallation costs; setup cost; diagnostic charges; periodic checkups; routine maintenance; loss of use of the product; costs or expenses arising out of reprogramming or loss of programming and/or data; shipping charges or fees; service calls; loss or damage occasioned by fire, theft, flood, wind, accident, abuse or misuse, and products subject to manufacturer's recall or similar event.

#### **8. DISPUTE RESOLUTION:**

Any controversy or claim arising out of or relating to SnapAV' Surge Protector Equipment Policy, or the alleged breach thereof, shall be settled by arbitration administered by the American Arbitration Association under its Commercial Arbitration Rules. You may file for arbitration at any AAA location in the United States upon the payment of the applicable filing fee. The arbitration will be conducted before a single arbitrator, and will be limited solely to the dispute or controversy between you and SnapAV. The arbitration shall be held in any mutually agreed upon location in person, by telephone, or online.

Any decision rendered in such arbitration proceedings will be final and binding on each of the parties, and judgment may be entered thereon in a court of competent jurisdiction. The arbitrator shall not award either party special, exemplary, consequential, punitive, incidental or indirect damages, or attorney's fees. The parties will share the costs of arbitration (including the arbitrator's fees, if any) in the proportion that the final award bears to the amount of the initial claim.

#### **9. GENERAL**

If you have any questions regarding the product warranty or the connected equipment protection policy, please contact the SnapAV Customer Service Department at [www.snapav.com/support](http://www.snapav.com/support). This warranty supersedes all previous warranties. This is the only warranty provided with the protector and any other implied or expressed warranties are nonexistent. This warranty may not be modified except in writing, signed by an officer of the SnapAV Corporation.

## **CONTACTING TECHNICAL SUPPORT**

**Phone:** (866) 838-5052 - **Email:** [Techsupport@snapav.com](mailto:Techsupport@snapav.com)

**WATT BOX**

engineered by   
**Snap**