

See Specifications for Individual Amounts

Key Features

Surge Protection with Fireproof MOVs – Advanced Ceramic MOV technology reduces risk of fire from surges.

Surge Disconnect – In the event of a catastrophic surge event, the WattBox™ component will sacrifice itself and permanently disconnect AC power.

Safe Voltage Monitoring – WattBox™ components equipped with Safe Voltage Monitoring will automatically disconnect system equipment from harmful over and under voltages. When the Input voltage returns to a safe level, the equipment will be reconnected.

Sequential Power – Protects against harmful speaker pop and blown circuits by sequentially turning equipment on and off

Noise Filtration – Eliminates AC noise to improve picture and sound quality.

Isolated Filtration Banks – Outlet banks are isolated from one another to prevent cross contamination between components.

High Current Outlets – Designed for equipment with high current demands such as amplifiers and subwoofers.

Welcome to Wattbox™

WattBox™ power products are designed specifically to provide customers with advanced protection for their valuable electronics and Custom Integrators with maximum flexibility for installation. With this IP-enabled power conditioner, both service calls and system downtime are reduced, and the self-healing Auto Reboot feature automatically resets components that become unresponsive on the network. Plus, you get a host of remote access features to monitor and control individual outlets – even receive email notifications that keep you informed about the system's status.

Rest assured that WattBox™ products will deliver the protection and safety for your customers' needs. All WattBox™ products are UL certified and built with the highest quality components available such as Fireproof MOVs. Whether in a rack, a structured wiring enclosure or behind a flat screen, the versatile mounting options allows simple installation of WattBox™ for easily managing power cords, adapters and signal cables. WattBox™ is the ideal choice for Custom Integrators who demand reliability, safety, and flexibility when installing power products for their valued customers.

Flexible Power Cord – WattBox™ power cords are both flexible and durable, and designed for ease of installation.

Secondary Protection – Protected 3 GHz signal coax/satellite connections plus Ethernet / Telephone connections.

Rack or Shelf Positioning – Flexible options allows for rack mounting or placement on a shelf. Rack ears and removable feet are included with every WattBox™ Chassis Model.

IP Control – Provides control of outlets over an IP network. Cycle outlet state and turn outlets on or off through a web browser.

Auto Reboot – Monitors network activity and resets power to outlets when programmable conditions are met.

Outlet Control Scheduling – Configure outlets to turn Off or On at a specific date or time.

System Notifications – Programmable email notifications keep you informed of System Status Changes.

See Positioning Options on Pg. 3.

Package Contents

- (1) WB-600CH-IPVCE-12
- (1) 6ft Power Cord
- (2) Rack Mounting Ears
- (8) Mounting Bracket Screws
- (1) CD-ROM (Wattbox Configuration Utility and manuals)
- (4) Removable Feet
- (2) Sheets of Power Cord Labels (16 total labels)
- (1) Owner's Manual
- (6) Power Adapter Hook & Loop Tie Down Straps

Front Panel

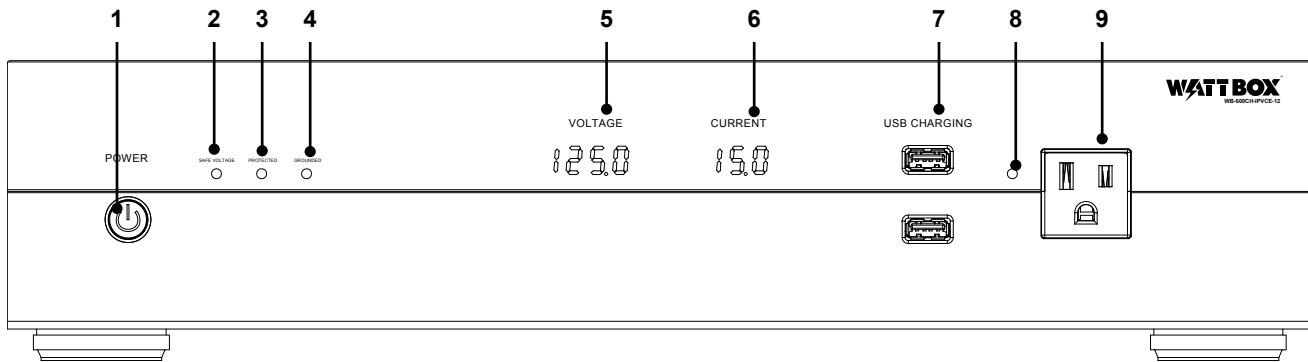

1. AC Power Switch (Momentary)
2. Safe Voltage LED Indicator
3. Surge Protection LED Indicator
4. Ground LED Indicator
5. Input Voltage Meter
6. Output Current Meter
7. USB Charging Ports
8. Utility Outlet Power Indicator
9. Utility AC Outlet (Protected)

Rear Panel

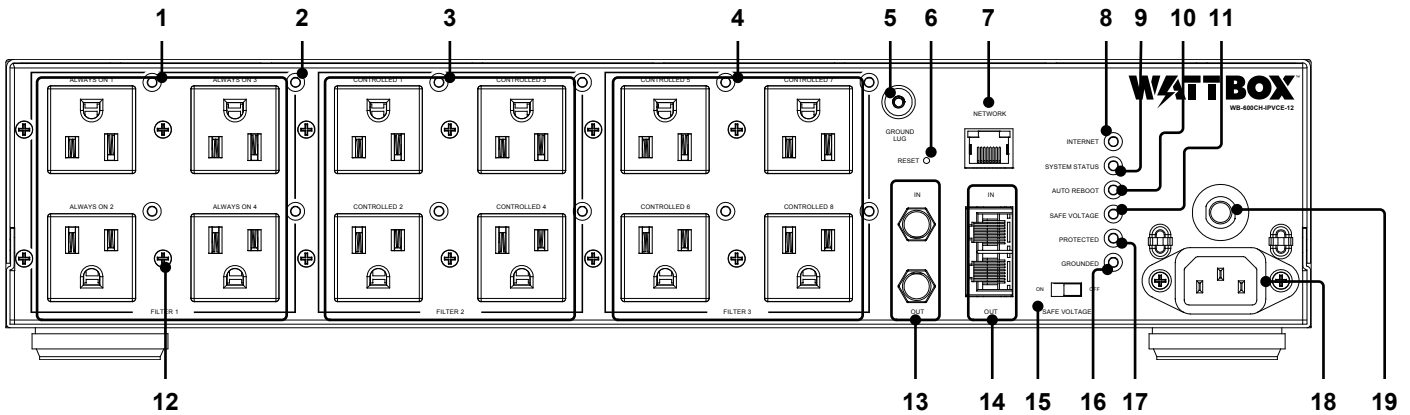

- | | |
|---|--|
| <ol style="list-style-type: none"> 1. Outlets 1 – 4 – Un-switched (Always On) Isolated Filter for video/network components 2. Outlet LED Power Indicator 3. Outlets 5 – 8 – Switched Isolated filter for audio/auxiliary 4. Outlets 9 – 12 Delayed/Isolated Filter for high current components 5. Ground Lug 6. Reset Button 7. RJ45 Network Connection (For IP Control) 8. Internet LED Indicator 9. System Status LED Indicator 10. Auto Reboot Enabled Indicator | <ol style="list-style-type: none"> 11. Safe Voltage LED indicator 12. Hook & Loop Strap Lockdown – See Securing Power Adapters on Pg. 4 13. Protected 3GHz coax connections for cable/satellite 14. Protected connections for Ethernet / Telephone 15. Safe voltage switch – Disables Safe Voltage Feature 16. Ground LED indicator 17. Surge Protection LED Indicator 18. Detachable power cord outlet with locking clip 19. 15 Amp resettable circuit breaker |
|---|--|

Positioning Options

The WattBox™ 600 Series is designed for placement on a shelf or mounting in standard 19" equipment racks. Both rack ears and feet are included so the decision can be made during installation.

Attach the brackets or feet to the WattBox™ depending on the desired application using the supplied hardware as illustrated below.

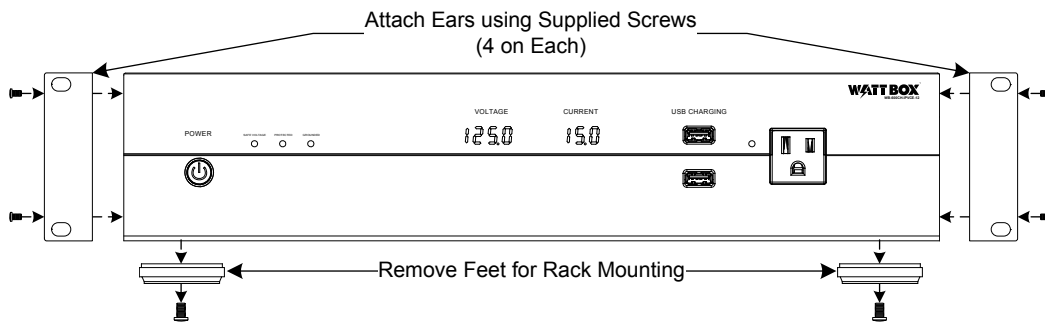

Note: Rack ears can be mounted towards the rear of the unit to for easy connection access.

Securing Power Adapters

The WattBox™ 600 series is supplied with hook & loop straps that can be used to secure power adapters the outlets.

1. Remove the screw on both sides of the outlet.
2. Insert the screw in the eyelet on the hook & loop straps.
3. Tighten the screw to secure the strap.
4. Wrap the hook & loop straps over the power adapter and fasten them together.

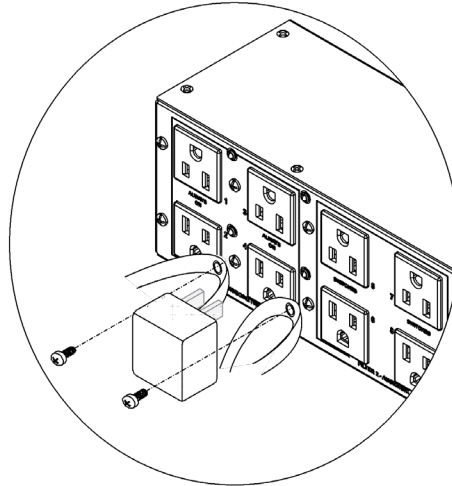

IP Connections

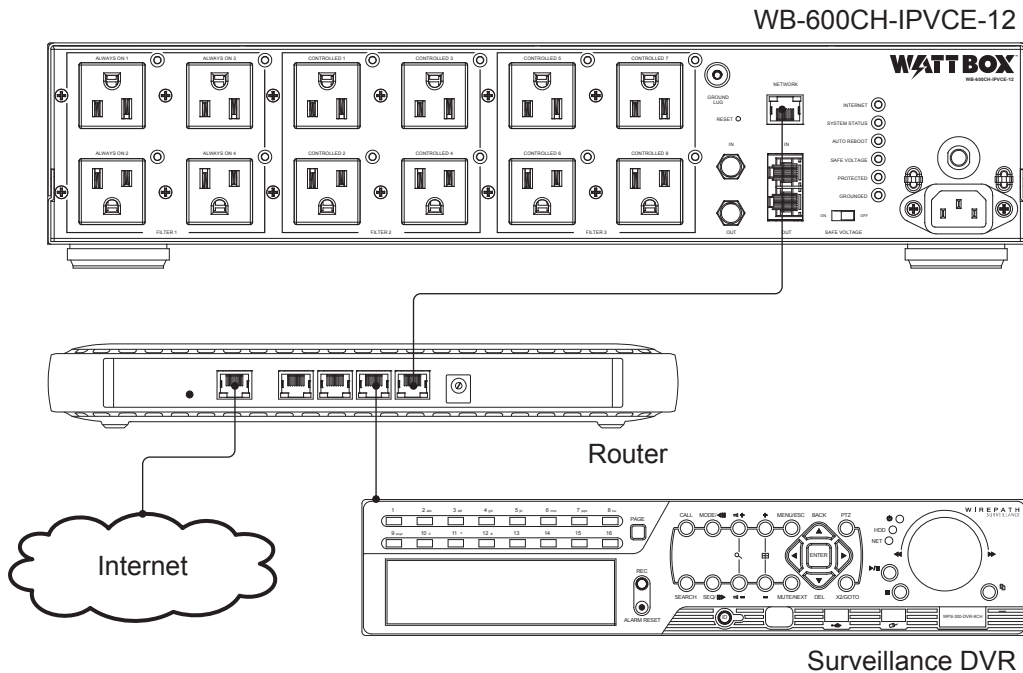

After connecting the **WB-600CH-IPVCE-12** to the network, configuration for IP control is performed using the Wattbox Utility. The utility and documentation on configuring the Wattbox can be found on the included CD Rom and the SnapAV website (www.SnapAV.com).

Note: The WattBox™ must be connected to the network and the router on before supplying power to the WattBox™.

Important Safety Instructions

Please read and observe the following safety points at all times.

WARNING – Power Sources

Do not plug this Component into a power outlet that differs from the source indicated for safe use on the Component. If you don't know the type of electrical power that is supplied to your home, consult your local power company or a qualified electrician.

WARNING – Grounding and Polarization

Do not force the Component plug into an outlet that is not designed to accept a three-wire grounded-type AC plug (a three-prong plug). This plug is designed to be inserted into a grounded-type outlet only. If this plug doesn't fit directly inside the outlet, do not attempt to force a connection. Never attempt to dismantle the plug in any way (or to alter the power cord). Do not attempt to defeat the grounding feature by using a 3-to-2 prong adapter. If you have questions about grounding, consult your local power company or a qualified electrician.

This Wattbox™ component requires a properly grounded outlet for safety and to protect connected equipment. If you're not sure if your home's electrical wiring is properly grounded, have it checked by a qualified electrician.

If any rooftop devices such as satellite dishes, antennas, or any other component with wire being used that connects to the Component, be sure the wire(s) is properly grounded. This protects against voltage surges and static charges.

Do not place any antenna near overhead power lines or any other power circuit. Do not touch any power line or power circuit. Doing so may cause severe physical injury or possibly death.

WARNING – Liquid: Avoiding Electrical Shocks

Do not operate the Component if liquid of any kind is spilled onto or inside the unit. Do not operate the Component near rain or water that's spilled or contained (e.g., bathtub, kitchen or sink).

WARNING – Power Cord Safety

When routing the Component's AC power cord, do not place it near heavy foot traffic areas (e.g., hallways, doorways, and floors). Do not create a trip hazard with the power cord.

If the power cord's protective jacket begins to rip or fray, exposing the internal wiring, shielding, etc., disconnect it from the AC power source and discontinue use of the Component immediately. See the Warranty Information section of this owner's manual for important details.

WARNING – No User Serviceable Parts Inside

If, for any reason, the Component is not operating properly, do not remove any part of the unit (cover, etc.) for repair. Unplug the unit and consult the Warranty Information section of this owner's manual for important details.

CAUTION – Exposure to Heat

Do not expose the Component to direct sunlight or place it near wall heaters, space heaters, or any enclosed space prone to temperature increase.

CAUTION – Proper Cleaning

In general, the only cleaning necessary for the Component is a light dusting. Unplug the Component from the wall outlet before cleaning it. Do not use any type of liquid or aerosol cleaners.

CAUTION – Earthing

Component should be installed by certified service personnel to ensure that the product is connected to a socket-outlet with a protective earthing connection

Troubleshooting

Symptom	Possible Cause	Remedy
The WattBox™ is not receiving power.	The WattBox™ is not turned On.	<ul style="list-style-type: none"> • Turn the WattBox™ switch on. • Make sure the WattBox™ AC power plug is plugged into a properly grounded 120 volts (nominal) wall outlet. • In some households, a wall switch may need to be turned on to make the wall outlet active. Try turning on the light switches located near the wall outlet.
	Too many devices are connected, causing an overload, tripping the Thermal Circuit Breaker.	<ul style="list-style-type: none"> • Press the WattBox™ resettable circuit breaker button in to reset. Please allow 10 minutes before attempting to reset. If you reset too soon, the breaker will prematurely sense power overload and not allow the WattBox™ to operate. • If the circuit breaker continues to trip, try moving one or more components to another WattBox™. You may be drawing too much current through one WattBox™.
Component is not receiving power.	The component is plugged into a switched outlet and the WattBox™ has not been turned On.	<ul style="list-style-type: none"> • Turn the WattBox™ On. • Or, plug the component into an unswitched outlet.
	The WattBox™ is plugged into a switched outlet, but power on the component is not On. In some instances, a component plugged into a switched outlet won't receive power when the WattBox™ is turned On unless the component power is also switched On.	<ul style="list-style-type: none"> • Turn the component power On.
Speakers emit a humming or buzzing noise.	The WattBox™ is sharing AC power with equipment that is not properly grounded.	<ul style="list-style-type: none"> • Connect your WattBox™ to a dedicated outlet. • Try unplugging different components from the WattBox™ one at a time to see if the noise stops. • If a component is discovered to be improperly grounded, attach a copper wire from the component's chassis to the WattBox™ grounding post.

Specifications

Outlets	
Type	NEMA 5-15
Number of Outlets	12
Always On	4 Outlets
IP Controlled	8 Outlets
AC Power	
Line Voltage	120V, 60Hz
AC Input Connection	IEC C-14
Power Cord Length	6 Feet
Circuit Breaker Rating	15A
UL Current Rating	12A
Voltage Protection Rating (UL 1449 3rd Edition)	500V
Joule Rating	6480 Joules
Surge Component	Ceramic Encased MOV
Protection Modes	L-N, L-G, N-G
Peak Impulse Current	396,000A
Disconnect Circuitry	Yes
Thermal Fuse	Yes
EMI / RFI Noise Filtration	
Filter Banks 1 & 2	80 dB, 300 kHz to 100 MHz
Filter Bank 3 (High Current)	80 dB, 300 kHz to 100 MHz
Safe Voltage Disconnect	
Over Voltage	138V AC +/- 5V AC
Under Voltage	88V AC +/- 5V AC
Cable / Satellite Circuit	
Connections	Gold Plated "F" Connector (1 Input and 1 Output)
Surge Component	Gas Tube
Clipping Voltage	600V
Frequency Range	0MHz - 3.0 GHz
Insertion Loss	< 0.5 dB
Shielded	Yes
Bi-directional	Yes
Phone / LAN Circuit	
Connections	RJ45 (1 Input and 1 Output)
Accepts	RJ11 & RJ45
Surge Component	Sidactor & MOV
Clipping Voltage	RJ11:400V; RJ45:250V
Wires Protected	8 Wires
Operating Temperature Range	14 to 104°F (-10 to +40°C)
UL Certifications	UL 60950-1, UL 1449, UL 498, UL 497A/B, UL 1283
Dimensions	17" W x 3.5" H x 12.5" D
Connected Equipment Warranty	\$50,000

Dimensions

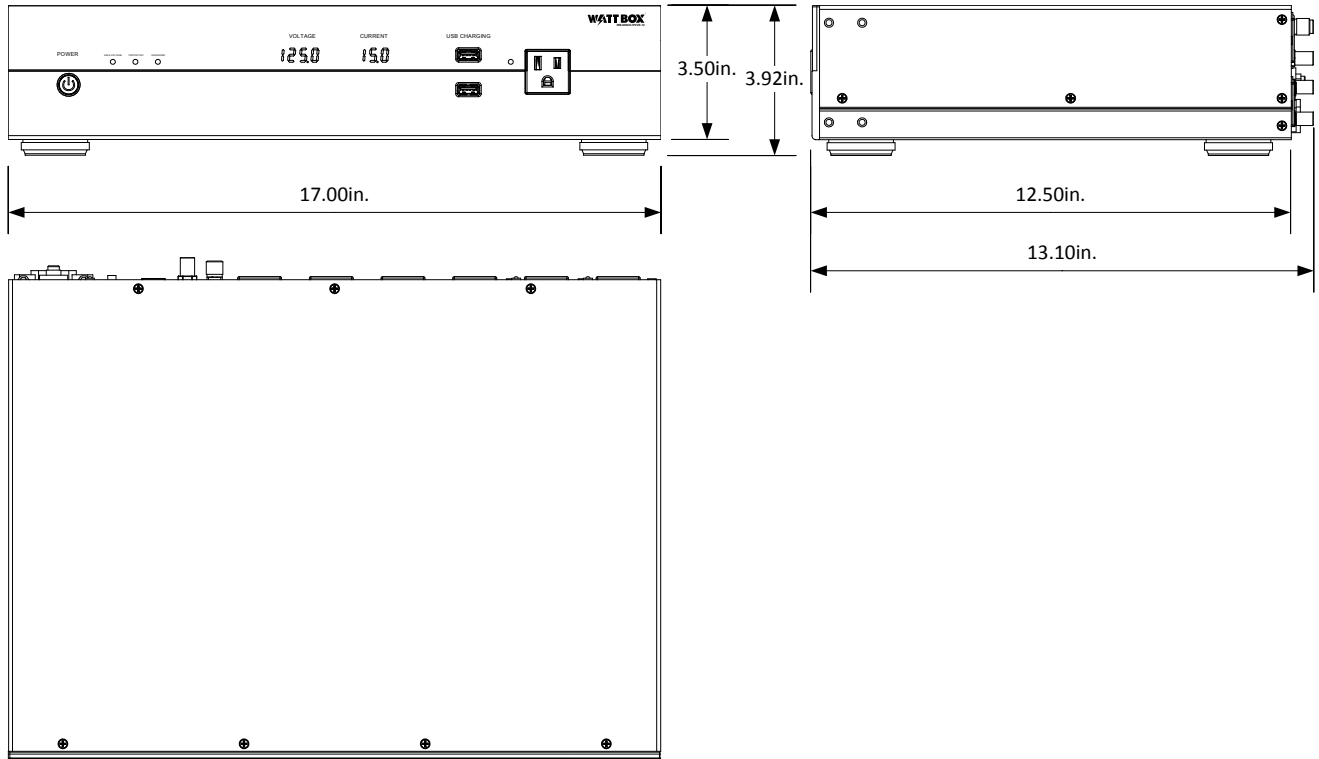

Warranty

Limited Lifetime Warranty

This SnapAV® product has a Lifetime Limited Warranty and a 5-Year Network Connectivity Warranty. The Lifetime Limited Warranty includes parts and labor repairs on all components found to be defective in material or workmanship under normal conditions of use. This warranty shall not apply to products which have been abused, modified or disassembled. Products to be repaired under this warranty must be returned to SnapAV or a designated service center with prior notification and an assigned return authorization number (RA).

Lifetime Replacement Policy

Valid only in the United States and Canada. If your SnapAV surge protector becomes damaged while protecting your connected equipment, you may request an equivalent replacement to the latest technology of that product category. Keep a copy of the original invoice to verify the product belongs to the original purchaser.

Warning Notice

WARRANTY LIMITATION FOR INTERNET PURCHASERS:

SnapAV products purchased outside of the SnapAV internet website do not carry a valid Connected Equipment Protection Policy unless purchased from an Authorized SnapAV Dealer.

CAUTION: Audio/Video, computer and/or telephone system installations can be very complex systems, which consist of many interconnected components. Due to the nature of electricity and surges, a single protector may not be able to completely protect complex installations. In those cases, a systemic approach using multiple protectors must be employed. Systemic protection requires professional design. AC power, satellite cables, CATV cables, or telephone/network lines entering the system that do not pass through this surge protector will render the SnapAV connected equipment protection policy null and void. For additional information on how to protect your system, please contact SnapAV before connecting your equipment to the surge protector.

THIS POLICY IS SUBJECT TO THE CONDITIONS BELOW:

1. PROOF OF PURCHASE REQUIRED:

SnapAV's connected equipment policy extends to the original purchaser of the SnapAV product only and is non-transferable.

Original purchase receipts must accompany any product return or claim for connected equipment damage.

2. PROPER INSTALLATION:

SnapAV AC protectors must be directly plugged into a properly grounded 3-wire AC outlet. Extension cords, non-grounded two prong adapters, or other non-SnapAV surge products must not be used. Building wiring and other connections to protected equipment must conform to applicable codes (NEC or CEC). No other ground wires or ground connections may be used. All wires (ie.g., AC power lines, telephone lines, signal/data lines, coaxial cable, etc.) leading into the protected equipment must first pass through a single SnapAV protector designed for the particular application. The protector and the equipment to be protected must be indoors in a dry location, and in the same building. SnapAV installation instructions and diagrams must be followed.

3. NOTIFICATION:

You must notify SnapAV within fourteen days of any event precipitating a request for product replacement or payment for connected equipment damage. A return authorization (RA) number must first be obtained from the SnapAV Customer Service Department at www.snapav.com/support before returning the protector to SnapAV. At this time, you must notify SnapAV if you believe you have a claim for damaged connected equipment.

Once you obtain a RA number, please mark the number on the bottom of the unit and pack it in a shipping carton/box with enough packing material to protect it during transit. The RA number must also be clearly marked on the outside of the carton. Ship the unit to SnapAV. Please note that you are responsible for any and all charges related to shipping the unit to SnapAV.

If connected equipment damage was indicated on your RA request, SnapAV will request the make and model of all connected equipment, a connection diagram of your system, as well as other requests based on the extent of the request for product placement or payment for connected equipment damage. All requests by SnapAV are to be completed and returned within 30 days. Be sure to note its configuration before disconnecting your equipment.

4. DETERMINATION OF FAILURE:

SnapAV will evaluate the protector for surge damage. The protector must show signs of surge damage or must be performing outside of design specifications relative to its surge protection capability. Opening the enclosure, tampering with, or modifying the unit in any way shall be grounds for an automatic denial of your request for payment. SnapAV, after evaluating all information provided, shall, in its sole discretion, determine whether or not your request is eligible for payment.

If the surge protector shows no signs of AC power or signal line surge damage and is working within design specifications, SnapAV will return the unit to you explaining the test results and notifying you of the rejection of your claim. SnapAV reserves the right to inspect the damaged connected equipment, parts, or circuit boards. SnapAV also reserves the right to inspect the customer's facility. Damaged equipment deemed uneconomical to repair must remain available for inspection by SnapAV until the claim is finalized.

5. REQUEST PAYMENTS:

Once SnapAV has determined that you are entitled to compensation, SnapAV will, at its election, pay you the present fair market value of the damaged equipment, or pay for the cost of the repair, or send you replacement equipment, or pay the equivalence of replacement equipment.

6. OTHER INSURANCE/WARRANTIES:

This coverage is secondary to any existing manufacturer's warranty, implied or expressed, or any insurance and/or service contract that may cover the loss.

7. EXCLUSIONS:

THE SNAPAV SURGE PROTECTOR EQUIPMENT POLICY DOES NOT APPLY TO: Service charges, installation costs, reinstallation costs; setup cost; diagnostic charges; periodic checkups; routine maintenance; loss of use of the product; costs or expenses arising out of reprogramming or loss of programming and/or data; shipping charges or fees; service calls; loss or damage occasioned by fire, theft, flood, wind, accident, abuse or misuse, and products subject to manufacturer's recall or similar event.

8. DISPUTE RESOLUTION:

Any controversy or claim arising out of or relating to SnapAV' Surge Protector Equipment Policy, or the alleged breach thereof, shall be settled by arbitration administered by the American Arbitration Association under its Commercial Arbitration Rules. You may file for arbitration at any AAA location in the United States upon the payment of the applicable filing fee. The arbitration will be conducted before a single arbitrator, and will be limited solely to the dispute or controversy between you and SnapAV. The arbitration shall be held in any mutually agreed upon location in person, by telephone, or online.

Any decision rendered in such arbitration proceedings will be final and binding on each of the parties, and judgment may be entered thereon in a court of competent jurisdiction. The arbitrator shall not award either party special, exemplary, consequential, punitive, incidental or indirect damages, or attorney's fees. The parties will share the costs of arbitration (including the arbitrator's fees, if any) in the proportion that the final award bears to the amount of the initial claim.

9. GENERAL

If you have any questions regarding the product warranty or the connected equipment protection policy, please contact the SnapAV Customer Service Department at www.snapav.com/support. This warranty supersedes all previous warranties. This is the only warranty provided with the protector and any other implied or expressed warranties are nonexistent. This warranty may not be modified except in writing, signed by an officer of the SnapAV Corporation.

Contacting Technical Support

Phone: (866) 838-5052

Email: Techsupport@snapav.com

WATT BOX

engineered by
Snap