

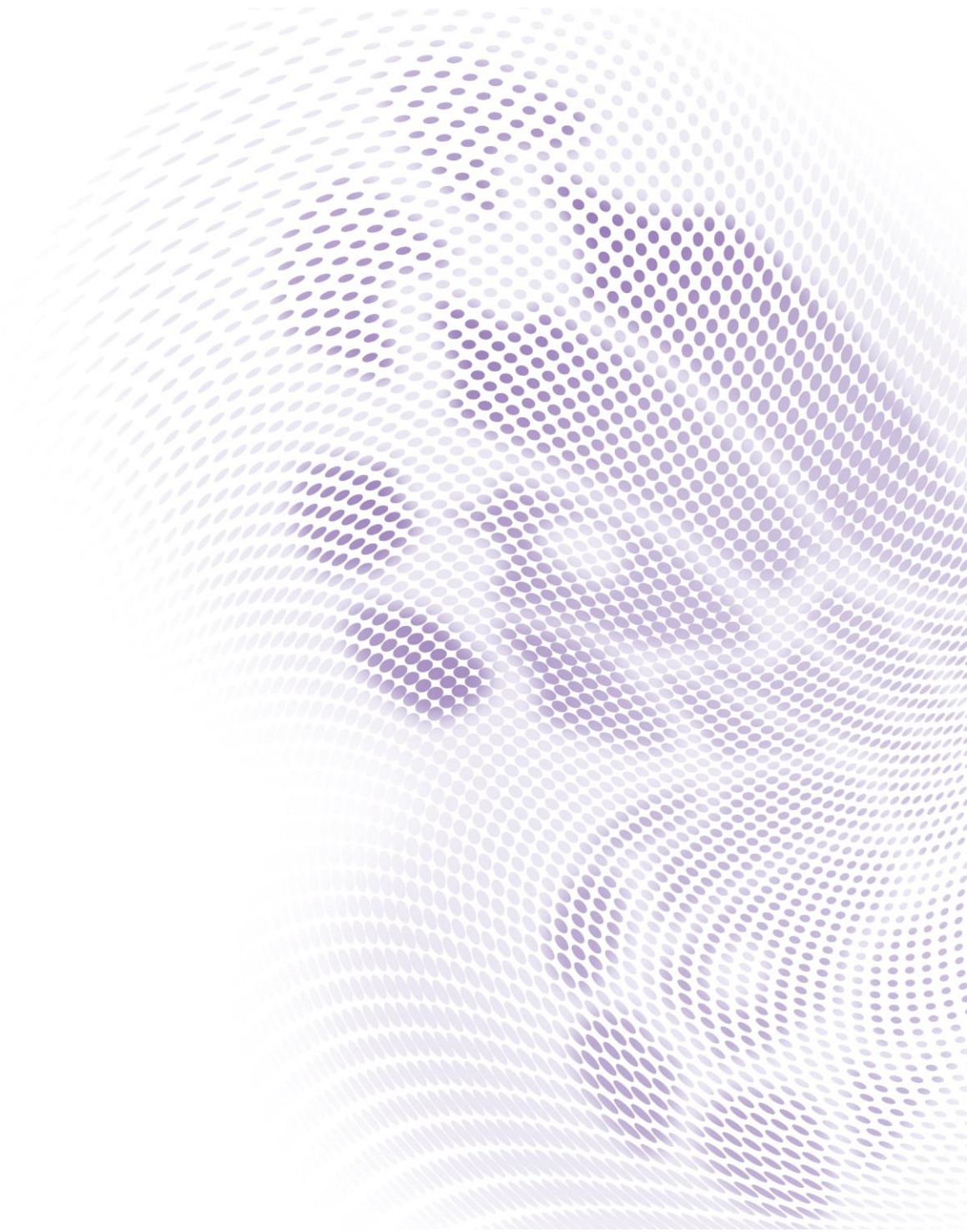

L930 Series

Projector RS232 Command Control

Installation Guide



# Table of Contents

Introduction .....	3
Wire arrangement.....	3
RS232 pin assignment.....	3
Connections and communication settings .....	4
RS232 serial port with a crossover cable .....	4
Settings .....	4
RS232 via LAN.....	6
Settings .....	6
RS232 via HDBaseT.....	6
Settings .....	6
Command table.....	8

# Introduction

The document describes how to control your BenQ projector via RS232 from a computer. Follow the procedures to complete the connection and settings first, and refer to the command table for RS232 commands.



Available functions and commands vary by model. Check the specifications and user manual of the purchased projector for product functions.

## Wire arrangement

Wire Arrangement		
P1	Color	P2
1	Black	1
2	Brown	3
3	Red	2
4	Orange	4
5	Yellow	5
6	Green	6
7	Blue	7
8	Purple	8
9	Gray	9
Case	Drain wire	Case

## RS232 pin assignment



Pin	Description	Pin	Description
1	NC	2	RXD
3	TXD	4	NC
5	GND	6	NC
7	RTS	8	CTS
9	NC		

# Connections and communication settings

Choose one of the connections and set up properly before RS232 control.

## RS232 serial port with a crossover cable

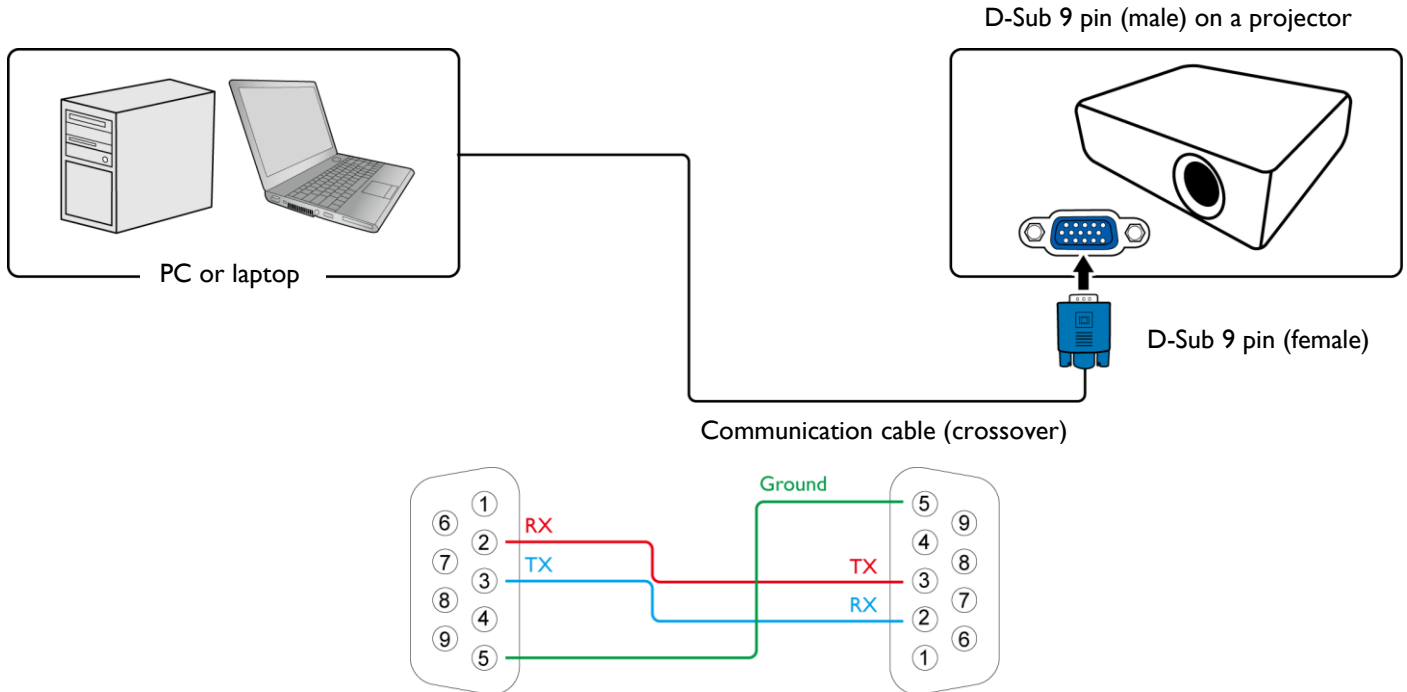

## Settings

 On-screen images in this document are for reference only. The screens may vary depending on your Operating System, I/O ports used for connection, and the specifications of the connected projector.

- I. Determine the COM Port name used for the RS232 communications in **Device Manager**.

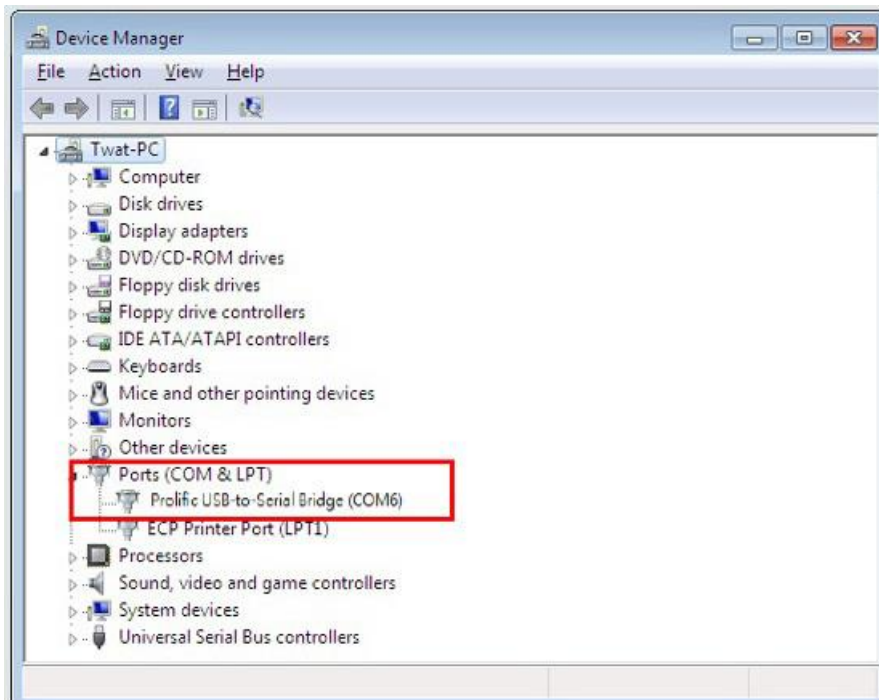

2. Choose **Serial** and the corresponding COM port as the communication port. In this given example, COM6 is selected.



3. Finish **Serial port setup**.

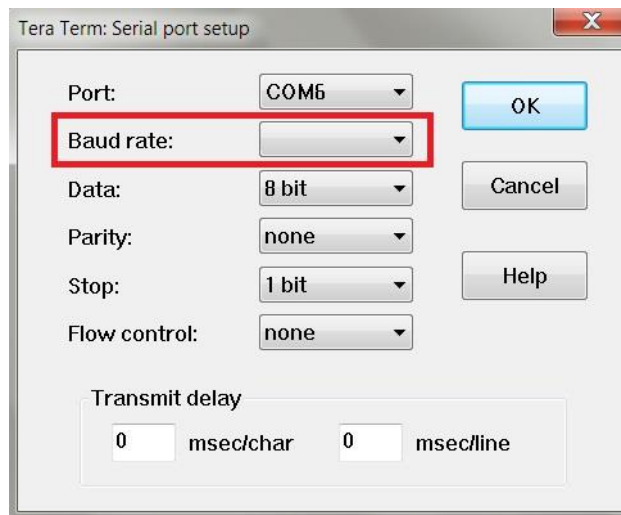

Baud rate	9600 / 14400 / 19200 / 38400 / 57600 / 115200 bps  Check the baud rate of the connected projector from its OSD menu.
Data length	8 bit
Parity check	None
Stop bit	1 bit
Flow control	None

## RS232 via LAN

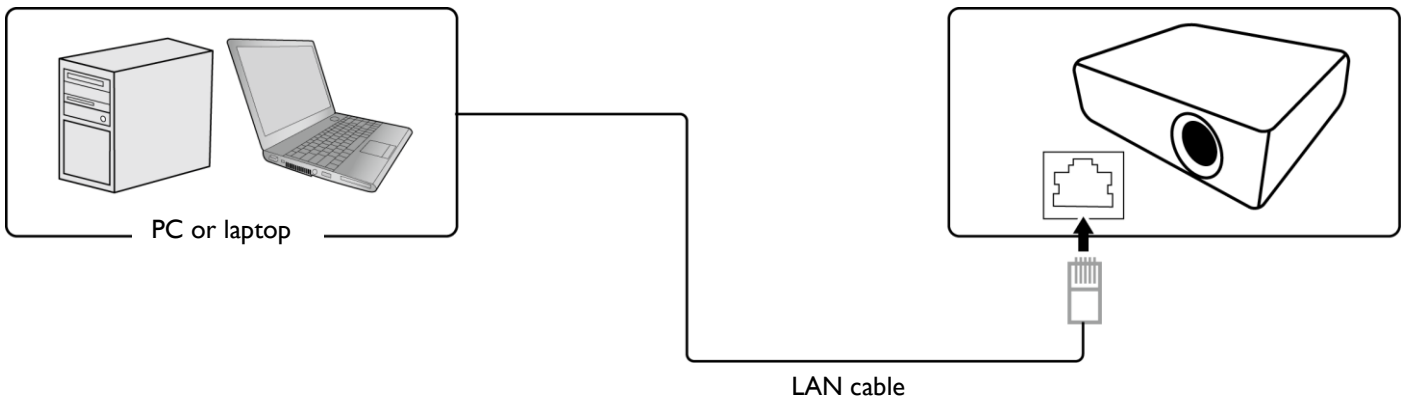

## Settings

1. Find the Wired LAN IP address of the connected projector from the OSD menu and make sure the projector and the computer are within the same network.
2. Input **8000** in the **TCP port #** field.



## RS232 via HDBaseT

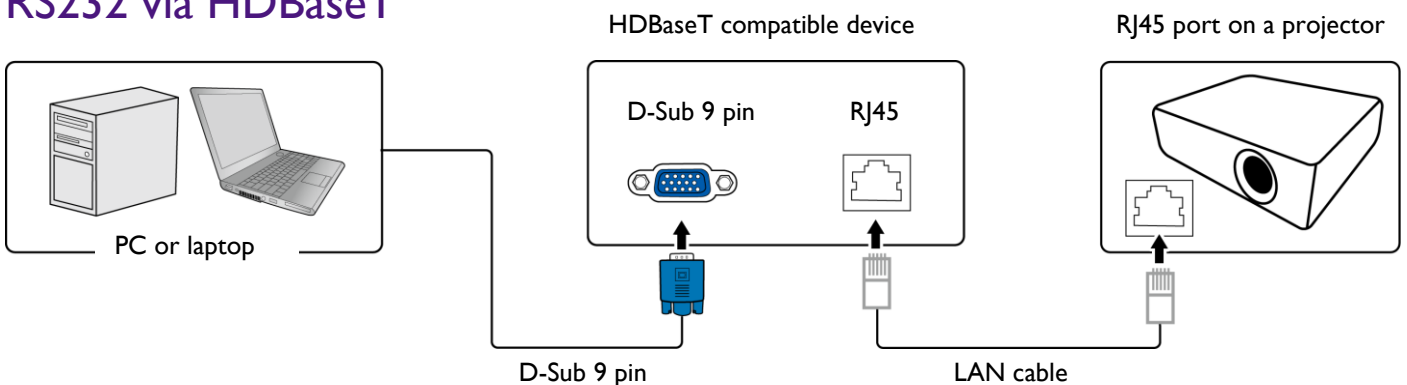



## Settings

1. Determine the COM Port name used for the RS232 communications in **Device Manager**.
2. Choose **Serial** and the corresponding COM port as the communication port. In this given example, COM6 is selected.

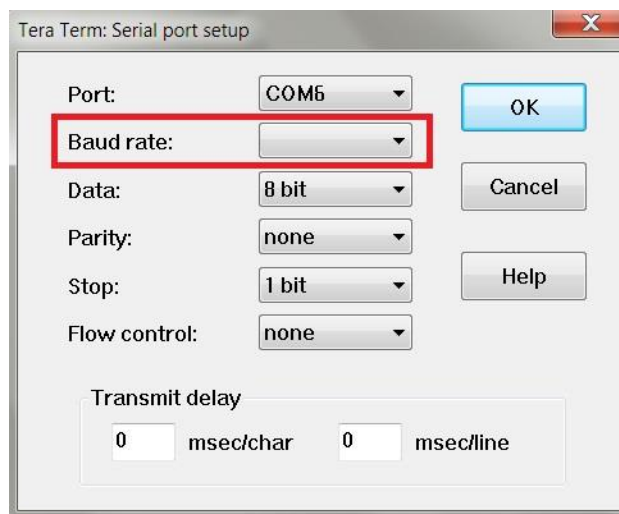

3. Finish **Serial** port setup.



Baud rate	9600 / 14400 / 19200 / 38400 / 57600 / 115200 bps  Check the baud rate of the connected projector from its OSD menu.
Data length	8 bit
Parity check	None
Stop bit	1 bit
Flow control	None



## Command table



- Available features differ by projector specification, input sources, settings, etc..
- Commands are working if the standby power is 0.5W or a supported baud rate of the projector is set.
- Uppercase, lowercase, and a mixture of both types of characters are accepted for a command.
- If a command format is illegal, it will echo **Illegal format**.
- If a command with correct format is not valid for the projector model, it will echo **Unsupported item**.
- If a command with correct format cannot be executed under certain condition, it will echo **Block item**.
- If RS232 control is performed via LAN, a command works whether it starts and ends with **<CR>**. All the commands and behaviors are identical with the control through a serial port.

Function	Type	Operation	ASCII	support
Power	Write	Power On	<CR>*pow=on#<CR>	YES
	Write	Power Off	<CR>*pow=off#<CR>	YES
	Read	Power Status	<CR>*pow=?#<CR>	YES
Source Selection	Write	COMPUTER/YPbPr	<CR>*sour=RGB#<CR>	YES
	Write	COMPUTER 2/YPbPr2	<CR>*sour=RGB2#<CR>	NO
	Write	COMPUTER 3/YPbPr3	<CR>*sour=RGB3#<CR>	NO
	Write	Component	<CR>*sour=ypbr#<CR>	YES
	Write	Component2	<CR>*sour=ypbr2#<CR>	NO
	Write	DVI-A	<CR>*sour=dviA#<CR>	NO
	Write	DVI-D	<CR>*sour=dvid#<CR>	NO
	Write	HDMI(MHL)	<CR>*sour=hdmi#<CR>	YES
	Write	HDMI 2(MHL2)	<CR>*sour=hdmi2#<CR>	YES
	Write	Composite	<CR>*sour=vid#<CR>	YES
	Write	S-Video	<CR>*sour=svid#<CR>	NO
	Write	Network	<CR>*sour=network#<CR>	NO
	Write	USB Display	<CR>*sour=usbdisplay#<CR>	NO
	Write	USB Reader	<CR>*sour=usbreader#<CR>	NO
	Write	HDbaseT	<CR>*sour=hdbaset#<CR>	NO
	Write	DisplayPort	<CR>*sour=dp#<CR>	NO
	Write	3G-SDI	<CR>*sour=sdi#<CR>	NO
	Write	Smart System	<CR>*sour=smartsystem#<CR>	NO
Read	Current source	<CR>*sour=?#<CR>	YES	
Audio Control	Write	Mute On	<CR>*mute=on#<CR>	YES
	Write	Mute Off	<CR>*mute=off#<CR>	YES
	Read	Mute Status	<CR>*mute=?#<CR>	YES
	Write	Volume +	<CR>*vol=+#<CR>	YES



	Write	Volume -	<CR>*vol=-#<CR>	YES
	Write	Volume level for customer	<CR>*vol=value#<CR>	YES
	Read	Volume Status	<CR>*vol=?#<CR>	YES
	Write	Mic.Volume +	<CR>*micvol=+#<CR>	NO
	Write	Mic.Volume -	<CR>*micvol=-#<CR>	NO
	Read	Mic.Volume Status	<CR>*micvol=?#<CR>	NO
Audio source select	Write	Audio pass Through off	<CR>*audiosour=off#<CR>	YES
	Write	Audio-Computer1	<CR>*audiosour=RGB#<CR>	YES
	Write	Audio-Computer2	<CR>*audiosour=RGB2#<CR>	NO
	Write	Audio-Video/S-Video	<CR>*audiosour=vid#<CR>	YES
	Write	Audio-Component	<CR>*audiosour=ypbr#<CR>	NO
	Write	Audio-HDMI	<CR>*audiosour=hdmi#<CR>	YES
	Write	Audio-HDMI2	<CR>*audiosour=hdmi2#<CR>	YES
	Read	Audio pass Status	<CR>*audiosour=?#<CR>	YES
Picture Mode	Write	Dynamic	<CR>*appmod=dynamic#<CR>	NO
	Write	Presentation	<CR>*appmod=preset#<CR>	YES
	Write	sRGB	<CR>*appmod=srgb#<CR>	YES
	Write	Bright	<CR>*appmod=bright#<CR>	YES
	Write	Living Room	<CR>*appmod=livingroom#<CR>	NO
	Write	Game	<CR>*appmod=game#<CR>	NO
	Write	Cinema	<CR>*appmod=cine#<CR>	NO
	Write	Standard/Vivid	<CR>*appmod=std#<CR>	NO
	Write	Football	<CR>*appmod=football#<CR>	NO
	Write	Football Bright	<CR>*appmod=footballbt#<CR>	NO
	Write	DICOM	<CR>*appmod=dicom#<CR>	NO
	Write	THX	<CR>*appmod=thx#<CR>	NO
	Write	Silence mode	<CR>*appmod=silence#<CR>	NO
	Write	DCI-P3 mode	<CR>*appmod=dci-p3#<CR>	NO
	Write	Vivid	<CR>*appmod=vivid#<CR>	YES
	Write	Infographic	<CR>*appmod=infographic#<CR>	YES
	Write	User1	<CR>*appmod=user1#<CR>	YES
	Write	User2	<CR>*appmod=user2#<CR>	YES
	Write	User3	<CR>*appmod=user3#<CR>	NO
	Write	ISF Day	<CR>*appmod=isfday#<CR>	NO
	Write	ISF Night	<CR>*appmod=isfnight#<CR>	NO
	Write	3D	<CR>*appmod=threed#<CR>	NO
Read	Picture Mode	<CR>*appmod=?#<CR>	YES	

Picture Setting	Write	Contrast +	<CR>*con=+#<CR>	YES
	Write	Contrast -	<CR>*con=-#<CR>	YES
	Write	Set Contrast value	<CR>*con=value#<CR>	YES
	Read	Contrast value	<CR>*con=?#<CR>	YES
	Write	Brightness +	<CR>*bri=+#<CR>	YES
	Write	Brightness -	<CR>*bri=-#<CR>	YES
	Write	Set Brightness value	<CR>*bri=value#<CR>	YES
	Read	Brightness value	<CR>*bri=?#<CR>	YES
	Write	Color +	<CR>*color=+#<CR>	YES
	Write	Color -	<CR>*color=-#<CR>	YES
	Write	Set Color value	<CR>*color=value#<CR>	YES
	Read	Color value	<CR>*color=?#<CR>	YES
	Write	Sharpness +	<CR>*sharp=+#<CR>	YES
	Write	Sharpness -	<CR>*sharp=-#<CR>	YES
	Write	Set Sharpness value	<CR>*sharp=value#<CR>	YES
	Read	Sharpness value	<CR>*sharp=?#<CR>	YES
	Write	Flesh Tone +	<CR>*fleshtone=+#<CR>	NO
	Write	Flesh Tone -	<CR>*fleshtone=-#<CR>	NO
	Write	Set Flesh Tone value	<CR>*fleshtone=value#<CR>	NO
	Read	Flesh Tone value	<CR>*fleshtone=?#<CR>	NO
	Write	Color Temperature-Warmer	<CR>*ct=warm#<CR>	NO
	Write	Color Temperature-Warm	<CR>*ct=warm#<CR>	YES
	Write	Color Temperature-Normal	<CR>*ct=normal#<CR>	YES
	Write	Color Temperature-Cool	<CR>*ct=cool#<CR>	YES
	Write	Color Temperature-Cooler	<CR>*ct=cooler#<CR>	NO
	Write	Color Temperature-lamp native	<CR>*ct=native#<CR>	NO
	Read	Color Temperature Status	<CR>*ct=?#<CR>	YES
	Write	Aspect 4:3	<CR>*asp=4:3#<CR>	YES
Write	Aspect 16:6	<CR>*asp=16:6#<CR>	NO	
Write	Aspect 16:9	<CR>*asp=16:9#<CR>	YES	

	Write	Aspect 16:10	<CR>*asp=16:10#<CR>	YES	
	Write	Aspect Auto	<CR>*asp=AUTO#<CR>	YES	
	Write	Aspect Real	<CR>*asp=REAL#<CR>	YES	
	Write	Aspect Letterbox	<CR>*asp=LBOX#<CR>	NO	
	Write	Aspect Wide	<CR>*asp=WIDE#<CR>	NO	
	Write	Aspect Anamorphic	<CR>*asp=ANAM#<CR>	NO	
	Write	Aspect Anamorphic 2.35	<CR>*asp=ANAM2.35#<CR>	NO	
	Write	Aspect Anamorphic 16:9	<CR>*asp=ANAM16:9#<CR>	NO	
	Read	Aspect Status	<CR>*asp=?#<CR>	YES	
	Write	Vertical Keystone +	<CR>*vkeystone=+#<CR>	YES	
	Write	Vertical Keystone -	<CR>*vkeystone=-#<CR>	YES	
	Read	Vertical Keystone value	<CR>*vkeystone=?#<CR>	YES	
	Write	Horizontal Keystone +	<CR>*hkeystone=+#<CR>	YES	
	Write	Horizontal Keystone -	<CR>*hkeystone=-#<CR>	YES	
	Read	Horizontal Keystone value	<CR>*hkeystone=?#<CR>	YES	
	Write	Overscan Adjustment +	<CR>*overscan=+#<CR>	NO	
	Write	Overscan Adjustment -	<CR>*overscan=-#<CR>	NO	
	Read	Overscan Adjustment value	<CR>*overscan=?#<CR>	NO	
	Operation Settings	Write	4 Corners Top-Left-X Decrease	<CR>*cornerfittlx=-#<CR>	YES
		Write	4 Corners Top-Left-X Increase	<CR>*cornerfittlx=+#<CR>	YES
Read		4 Corners Top-Left-X Status	<CR>*cornerfittlx=?#<CR>	YES	
Write		4 Corners Top-Left-Y Decrease	<CR>*cornerfittly=-#<CR>	YES	
Write		4 Corners Top-Left-Y Increase	<CR>*cornerfittly=+#<CR>	YES	
Read		4 Corners Top-Left-Y Status	<CR>*cornerfittly=?#<CR>	YES	
Write		4 Corners Top-Right-X Decrease	<CR>*cornerfittrx=-#<CR>	YES	
Write	4 Corners Top-Right-X	<CR>*cornerfittrx=+#<CR>	YES		

		Increase		
Read	4 Corners Top-Right-X Status		<CR>*cornerfittrx=?#<CR>	YES
Write	4 Corners Top-Right-Y Decrease		<CR>*cornerfittry=-#<CR>	YES
Write	4 Corners Top-Right-Y Increase		<CR>*cornerfittry=+#<CR>	YES
Read	4 Corners Top-Right-Y Status		<CR>*cornerfittry=?#<CR>	YES
Write	4 Corners Bottom-Left-X Decrease		<CR>*cornerfitblx=-#<CR>	YES
Write	4 Corners Bottom-Left-X Increase		<CR>*cornerfitblx=+#<CR>	YES
Read	4 Corners Bottom-Left-X Status		<CR>*cornerfitblx=?#<CR>	YES
Write	4 Corners Bottom-Left-Y Decrease		<CR>*cornerfitbly=-#<CR>	YES
Write	4 Corners Bottom-Left-Y Increase		<CR>*cornerfitbly=+#<CR>	YES
Read	4 Corners Bottom-Left-Y Status		<CR>*cornerfitbly=?#<CR>	YES
Write	4 Corners Bottom-Right-X Decrease		<CR>*cornerfitbrx=-#<CR>	YES
Write	4 Corners Bottom-Right-X Increase		<CR>*cornerfitbrx=+#<CR>	YES
Read	4 Corners Bottom-Right-X Status		<CR>*cornerfitbrx=?#<CR>	YES
Write	4 Corners Bottom-Right-Y Decrease		<CR>*cornerfitbry=-#<CR>	YES
Write	4 Corners Bottom-Right-Y Increase		<CR>*cornerfitbry=+#<CR>	YES

		Increase		
	Read	4 Corners Bottom-Right-Y Status	<CR>*cornerfitbry=?#<CR>	YES
	Write	Digital Zoom In	<CR>*zoomI#<CR>	YES
	Write	Digital Zoom out	<CR>*zoomO#<CR>	YES
	Write	Auto	<CR>*auto#<CR>	YES
	Write	Brilliant color on	<CR>*BC=on#<CR>	YES
	Write	Brilliant color off	<CR>*BC=off#<CR>	YES
	Read	Brilliant color status	<CR>*BC=?#<CR>	YES
	Write	Reset picture settings	<CR>*rstpicsetting#<CR>	YES
	Write	Projector Position-Front Table	<CR>*pp=FT#<CR>	YES
	Write	Projector Position-Rear Table	<CR>*pp=RE#<CR>	YES
	Write	Projector Position-Rear Ceiling	<CR>*pp=RC#<CR>	YES
	Write	Projector Position-Front Ceiling	<CR>*pp=FC#<CR>	YES
	Read	Projector Position Status	<CR>*pp=?#<CR>	YES
	Write	Quick cooling on	<CR>*qcool=on<CR>	NO
	Write	Quick cooling off	<CR>*qcool=off<CR>	NO
	Read	Quick cooling status	<CR>*qcool=?<CR>	NO
	Write	Quick auto search	<CR>*QAS=on#<CR>	YES
	Write	Quick auto search	<CR>*QAS=off#<CR>	YES
	Read	Quick auto search status	<CR>*QAS=?#<CR>	YES
	Write	Menu Position - Center	<CR>*menuposition=center#<CR>	NO
	Write	Menu Position - Top-Left	<CR>*menuposition=tl#<CR>	NO
	Write	Menu Position - Top-Right	<CR>*menuposition=tr#<CR>	NO
	Write	Menu Position - Bottom-Right	<CR>*menuposition=br#<CR>	NO
	Write	Menu Position - Bottom-Left	<CR>*menuposition=bl#<CR>	NO
	Read	Menu Position Status	<CR>*menuposition=?#<CR>	NO

	Write	Direct Power On-on	<CR>*directpower=on#<CR>	YES
	Write	Direct Power On-off	<CR>*directpower=off#<CR>	YES
	Read	Direct Power On-Status	<CR>*directpower=?#<CR>	YES
	Write	Signal Power On-on	<CR>*autopower=on#<CR>	YES
	Write	Signal Power On-off	<CR>*autopower=off#<CR>	YES
	Read	Signal Power On-Status	<CR>*autopower=?#<CR>	YES
	Write	Standby Settings-Network on	<CR>*standbynet=on#<CR>	YES
	Write	Standby Settings-Network off	<CR>*standbynet=off#<CR>	YES
	Read	Standby Settings-Network Status	<CR>*standbynet=?#<CR>	YES
	Write	Standby Settings-Microphone on	<CR>*standbymic=on#<CR>	NO
Baud Rate Lamp Control Miscellaneous	Write	Standby Settings-Microphone off	<CR>*standbymic=off#<CR>	NO
	Read	Standby Settings-Microphone Status	<CR>*standbymic=?#<CR>	NO
	Write	Standby Settings-Monitor Out on	<CR>*standbymnt=on#<CR>	YES
	Write	Standby Settings-Monitor Out off	<CR>*standbymnt=off#<CR>	YES
	Read	Standby Settings-Monitor Out Status	<CR>*standbymnt=?#<CR>	YES
	Write	2400	<CR>*baud=2400#<CR>	NO
	Write	4800	<CR>*baud=4800#<CR>	NO
	Write	9600	<CR>*baud=9600#<CR>	YES
	Write	14400	<CR>*baud=14400#<CR>	YES
	Write	19200	<CR>*baud=19200#<CR>	YES

Write	38400	<CR>*baud=38400#<CR>	YES
Write	57600	<CR>*baud=57600#<CR>	YES
Write	115200	<CR>*baud=115200#<CR>	YES
Read	Current Baud Rate	<CR>*baud=?#<CR>	YES
Read	Lamp	<CR>*ltim=?#<CR>	YES
Read	Lamp2 Hour	<CR>*ltim2=?#<CR>	NO
Write	Normal mode	<CR>*lampm=lnor#<CR>	YES
Write	Eco mode	<CR>*lampm=eco#<CR>	YES
Write	SmartEco mode	<CR>*lampm=seco#<CR>	NO
Write	SmartEco mode 2	<CR>*lampm=seco2#<CR>	NO
Write	SmartEco mode 3	<CR>*lampm=seco3#<CR>	NO
Write	LampSave+ mode	<CR>*lampm=lampsave+#<CR>	NO
Write	Dimming mode	<CR>*lampm=dimming#<CR>	YES
Write	Custom mode	<CR>*lampm=custom#<CR>	YES
Write	Light level for custom mode	<CR>*lampcustom=value#<CR>	YES
Read	Light level status for custom mode	<CR>*lampcustom=?#<CR>	YES
Write (dual lamps)	Dual Brightest	<CR>* lampm =dualbr#<CR>	NO
Write (dual lamps)	Dual Reliable	<CR>* lampm =dualre#<CR>	NO
Write (dual lamps)	Single Alternative	<CR>* lampm =single#<CR>	NO
Write (dual lamps)	Single Alternative Eco	<CR>* lampm =singleeco#<CR>	NO
Read	Lamp Mode Status	<CR>*lampm=?#<CR>	YES
Read	Model Name	<CR>*modelname=?#<CR>	YES
Read	System F/W Version	<CR>*sysfwversion=?#<CR>	YES
Read	Scaler F/W Version	<CR>*scalerfwversion=?#<CR>	YES
Read	Lan F/W Version	<CR>*lanfwversion=?#<CR>	YES
Read	MCU F/W Version	<CR>*mcutfwversion=?#<CR>	YES
Read	Ballast F/W Version	<CR>*ballastfwversion=?#<CR>	YES
Write	Blank On	<CR>*blank=on#<CR>	YES



Write	Blank Off	<CR>*blank=off#<CR>	YES
Read	Blank Status	<CR>*blank=?#<CR>	YES
Write	Freeze On	<CR>*freeze=on#<CR>	YES
Write	Freeze Off	<CR>*freeze=off#<CR>	YES
Read	Freeze Status	<CR>*freeze=?#<CR>	YES
Write	Menu On	<CR>*menu=on#<CR>	YES
Write	Menu Off	<CR>*menu=off#<CR>	YES
Read	Menu Status	<CR>*menu=?#<CR>	YES
Write	Up	<CR>*up#<CR>	YES
Write	Down	<CR>*down#<CR>	YES
Write	Right	<CR>*right#<CR>	YES
Write	Left	<CR>*left#<CR>	YES
Write	Enter	<CR>*enter#<CR>	YES
Write	Back	<CR>*back#<CR>	YES
Write	Source Menu On	<CR>*sourmenu=on#<CR>	YES
Write	Source Menu Off	<CR>*sourmenu=off#<CR>	YES
Read	Source Menu Status	<CR>*sourmenu=?#<CR>	YES
Write	3D Sync Off	<CR>*3d=off#<CR>	YES
Write	3D Auto	<CR>*3d=auto#<CR>	YES
Write	3D Sync Top Bottom	<CR>*3d=tb#<CR>	YES
Write	3D Sync Frame Sequential	<CR>*3d=fs#<CR>	YES
Write	3D Frame packing	<CR>*3d=fp#<CR>	YES
Write	3D Side by side	<CR>*3d=sbs#<CR>	YES
Write	3D inverter disable	<CR>*3d=da#<CR>	YES
Write	3D inverter	<CR>*3d=iv#<CR>	YES
Write	2D to 3D	<CR>*3d=2d3d#<CR>	NO
Write	3D nVIDIA	<CR>*3d=nvidia#<CR>	NO
Read	3D Sync Status	<CR>*3d=?#<CR>	YES
Write	Remote Receiver On	<CR>*rr=on#<CR>	NO
Write	Remote Receiver Off	<CR>*rr=off#<CR>	NO
Write	Remote Receiver-front+rear	<CR>*rr=fr#<CR>	NO
Write	Remote Receiver-front	<CR>*rr=f#<CR>	YES
Write	Remote Receiver-rear	<CR>*rr=r#<CR>	NO
Write	Remote Receiver-top	<CR>*rr=t#<CR>	YES
Write	Remote Receiver-top+front	<CR>*rr=tf#<CR>	YES

	Write	Remote Receiver-top+rear	<CR>*rr=tr#<CR>	NO
	Read	Remote Receiver Status	<CR>*rr=?#<CR>	YES
	Write	Instant On-on	<CR>*ins=on#<CR>	NO
	Write	Instant On-off	<CR>*ins=off#<CR>	NO
	Read	Instant On Status	<CR>*ins=?#<CR>	NO
	Write	Lamp Saver Mode-on	<CR>*lpsaver=on#<CR>	NO
	Write	Lamp Saver Mode-off	<CR>*lpsaver=off#<CR>	NO
	Read	Lamp Saver Mode Status	<CR>*lpsaver=?#<CR>	NO
	Write	Projection Log In Code on	<CR>*prjlogincode=on#<CR>	NO
	Write	Projection Log In Code off	<CR>*prjlogincode=off#<CR>	NO
	Read	Projection Log In Code Status	<CR>*prjlogincode=?#<CR>	NO
	Write	Broadcasting on	<CR>*broadcasting=on#<CR>	NO
	Write	Broadcasting off	<CR>*broadcasting=off#<CR>	NO

BenQ.com

© 2018 BenQ Corporation

All rights reserved. Rights of modification reserved.

Version: 1.01-C