



X300 Output Control Expansion Module Installation Guide

ADC-AC-X300

Only compatible
with HID Aero Series
controllers





Have you taken the Smarter Access Control training course yet?

This course is recommended for every installer and is required for three reps per Service Provider before Access Control hardware can be added to an Alarm.com account. The course should be completed at least 48 hours before the first customer installation begins.

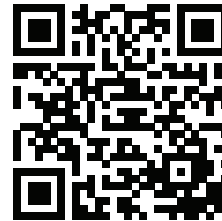

Already familiar with Smarter Access Control? Great! You can take the **Fast Track training assessment** to complete the training requirement.

All training can be found here: <https://academy.alarm.com/series/access-control> or by scanning the QR code above in MobileTech.

X300 Output Control Expansion Module

The ADC-AC-X300 expansion module provides a solution for controlling twelve additional outputs. Three dedicated inputs are provided for Tamper, AC Fail, and Battery Fail. Two inputs are provided and can be configured as unsupervised or supervised using end-of-line resistors. Communication to the X1100 Door Controller is accomplished using a 2-wire RS-485 interface. The ADC-AC-X300 requires 12-24 VDC for power. See the following figure for component location.

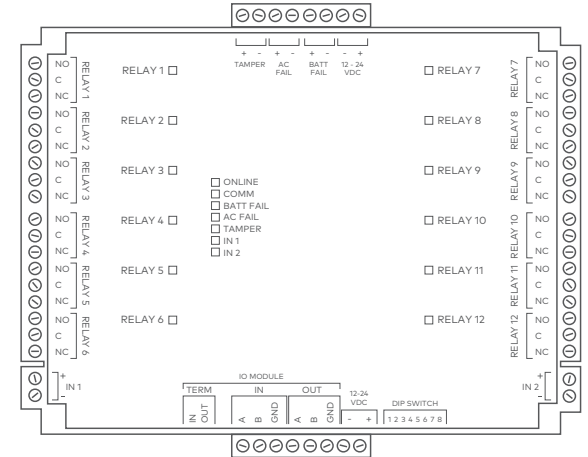

Wiring

Connections

TB1-1	RELAY 1	NO	Relay 1 Normally Open Contact
TB1-2		C	Relay 1 Common Contact
TB1-3		NC	Relay 1 Normally Closed Contact
TB1-4	RELAY 2	NO	Relay 2 Normally Open Contact
TB1-5		C	Relay 2 Common Contact
TB1-6		NC	Relay 2 Normally Closed Contact
TB1-7	RELAY 3	NO	Relay 3 Normally Open Contact
TB1-8		C	Relay 3 Common Contact
TB1-9		NC	Relay 3 Normally Closed Contact
TB2-1	RELAY 4	NO	Relay 4 Normally Open Contact
TB2-2		C	Relay 4 Common Contact
TB2-3		NC	Relay 4 Normally Closed Contact

TB2-4	RELAY 5	NO	Relay 5 Normally Open Contact
TB2-5		C	Relay 5 Common Contact
TB2-6		NC	Relay 5 Normally Closed Contact
TB2-7	RELAY 6	NO	Relay 6 Normally Open Contact
TB2-8		C	Relay 6 Common Contact
TB2-9		NC	Relay 6 Normally Closed Contact
TB3-1	INPUT 1	IN+	Input 1
TB3-2		IN-	
TB4-1	RELAY 7	NO	Relay 7 Normally Open Contact
TB4-2		C	Relay 7 Common Contact
TB4-3		NC	Relay 7 Normally Closed Contact

TB4-4	RELAY 8	NO	Relay 8 Normally Open Contact
TB4-5		C	Relay 8 Common Contact
TB4-6		NC	Relay 8 Normally Closed Contact
TB4-7	RELAY 9	NO	Relay 9 Normally Open Contact
TB4-8		C	Relay 9 Common Contact
TB4-9		NC	Relay 9 Normally Closed Contact
TB5-1	RELAY 10	NO	Relay 10 Normally Open Contact
TB5-2		C	Relay 10 Common Contact
TB5-3		NC	Relay 10 Normally Closed Contact
TB5-4	RELAY 11	NO	Relay 11 Normally Open Contact
TB5-5		C	Relay 11 Common Contact
TB5-6		NC	Relay 11 Normally Closed Contact

TB5-7	RELAY 12	NO	Relay 12 Normally Open Contact
TB5-8		C	Relay 12 Common Contact
TB5-9		NC	Relay 12 Normally Closed Contact
TB6-1	INPUT 2	IN+	Input 2
TB6-2		IN-	
TB7-1	TMP	TMP+	Tamper
TB7-2		TMP-	
TB7-3	AC	AC+	AC Fail
TB7-4		AC-	
TB7-5	BT	BT+	Battery Fail
TB7-6		BT-	

Status LEDs

TB7-7	12-24 VDC	GND	Input Power Ground
TB7-8		VIN	Input Power Ground (from local power)
TB8-1	EXPANSION IN	TR+	IO Module Port 1
TB8-2		TR-	
TB8-3		GND	
TB8-4	EXPANSION OUT	TR+	IO Module Port 2
TB8-5		TR-	
TB8-6		GND	
TB8-7	12-24 VDC	GND	Input Power Ground
TB8-8		VIN	Input Power Ground (from local power)

LED Label	Represents	Initialization	Normal Operation
A	ONLINE	ON then OFF	Heartbeat and Online status Offline = 1 sec rate, 20% ON Online = Blinks ON/OFF for 0.7s, ON for 0.3s
B	COMM	ON then OFF	Indicates communication activity on expansion module communication port
BAT	BATT FAIL	ON then OFF	OFF = Inactive, ON = Active, Flash = Fault*

AC	AC FAIL	ON then OFF	OFF = Inactive, ON = Active, Flash = Fault*
TMP	TAMPER	ON then OFF	OFF = Inactive, ON = Active, Flash = Fault*
IN1	IN 1	ON then OFF	OFF = Inactive, ON = Active, Flash = Fault*
IN2	IN 2	ON then OFF	OFF = Inactive, ON = Active, Flash = Fault*
D22	RELAY 1	OFF	ON = Energized
D23	RELAY 2	OFF	ON = Energized
D24	RELAY 3	OFF	ON = Energized

D25	RELAY 4	OFF	ON = Energized
D26	RELAY 5	OFF	ON = Energized
D27	RELAY 6	OFF	ON = Energized
D28	RELAY 7	OFF	ON = Energized
D29	RELAY 8	OFF	ON = Energized
D30	RELAY 9	OFF	ON = Energized
D31	RELAY 10	OFF	ON = Energized
D32	RELAY 11	OFF	ON = Energized
D33	RELAY 12	OFF	ON = Energized

Communication wiring

The ADC-AC-X300 communicates to an X1100 Door Controller using a 2-wire RS-485 interface. The ADC-AC-X300 allows for multi-drop communication on a bus of up to 4,000 feet (1,219 m). Use twisted pair (minimum 24 AWG) with drain wire and shield for communication. If the ADC-AC-X300 is the last device on the communication bus, jumper **J1** must be set to "IN".

Note: Both Port 1 and Port 2 terminals for the Expansion Module ports are the same port and are internally connected.

RS-485 Wiring using the ADC-AC-X1100 Door Controller

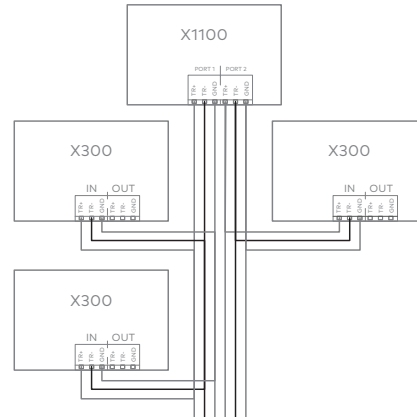

For ease of install, daisy chain expansion modules together. Wire each expansion module to the next module instead of wiring directly back to the controller.

Install jumpers according to the selected configuration

- If there are additional downstream expansion modules, set jumper to "OUT"
- If this is the last device on the communication bus, set jumper to "IN"

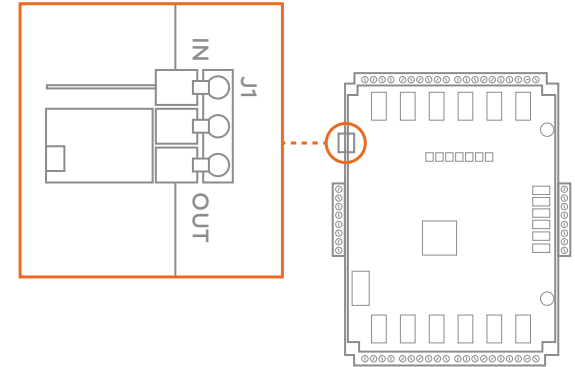

Addressing

Flip the DIP switches on the the ADC-AC-X300 expansion module according to the "Jumpers/Switches ON" column in the Access Control Devices table on the Alarm.com Partner Portal (or MobileTech). These DIP switches are also displayed in the "Add Expansion Module" installation wizard. If these DIP switches are not set according to the Partner Portal (or MobileTech), the device and its connected readers and door hardware will not function properly with Alarm.com.

Relay Wiring

Twelve Form-C contact relays are provided for controlling door lock mechanisms. Each relay has a Common pole (C), a Normally Open pole (NO), and a Normally Closed pole (NC). When momentarily delivering power to unlock the locking hardware (fail secure), the Normally Open and Common poles are used. When momentarily removing power to unlock the locking hardware (failsafe), the Normally Closed and Common poles are used. Check with local building codes for proper egress door installation. 18 AWG minimum recommended for electric locking hardware.

Note: Load switching can cause abnormal contact wear and premature contact failure. Switching of inductive loads (strike) also causes EMI (electromagnetic interference), which may interfere with normal operation of other equipment.

To minimize premature contact failure and to increase system reliability, a contact protection circuit may be used. The following circuit is recommended. Locate the protection circuit as close to the load as possible (within 12 inches [30 cm]), as the effectiveness of the circuit will decrease if it is located further away.

Use sufficiently large gauge wires for the load current to avoid voltage loss.

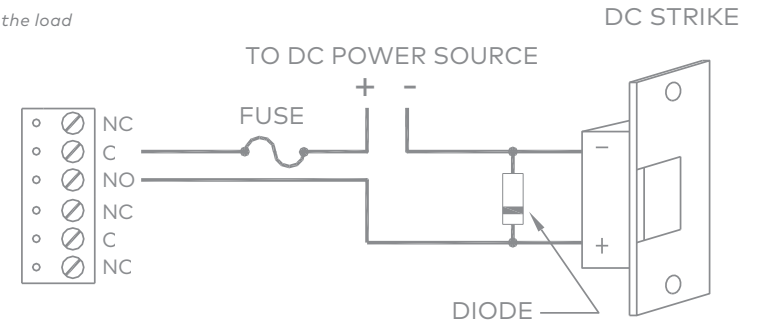

Diode Selection

- Diode current rating: 1x strike current
- Diode breakdown voltage: 4x strike voltage
- For 12 VDC or 24 VDC strike, diode 1N4002 (100 V / 1 A) typical

Input Wiring

There are two inputs that can be used to monitor door position, request-to-exit, or alarm contact devices. Input circuits can be configured as Unsupervised (2 states): reporting as open or closed contact, or Supervised (6 states): reporting as open or closed contact, open circuit, shorted circuit, grounded circuit, or foreign voltage.

A supervised input circuit requires adding two resistors with value of 1k ohm, 1% to the circuit to facilitate proper reporting and should be located as close to the sensor as possible.

The input circuit wiring configurations shown are supported but may not be typical.

22 AWG minimum required for input wiring. 18 AWG recommended if wiring request-to-exit devices in series with locking hardware.

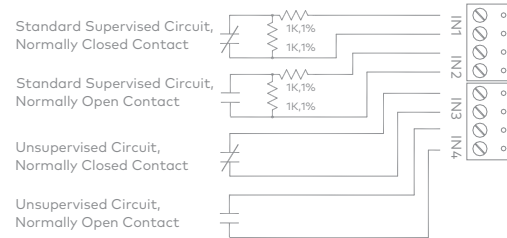

Note: Either the top or bottom 12-24 V terminals can be used to power the board.

Specifications

The interface is for use in low voltage, Class 2 circuits only. The installation of this device must comply with all local fire and electrical codes.

Input power

12 to 24 VDC $\pm 10\%$, 500 mA max input current

Communication

2-Wire RS-485

Inputs

2 unsupervised/supervised programmable inputs, standard EOL: 1k/1k Ω , 1%, ¼ watt
One dedicated input for each:
Tamper, AC Fail, Batt Fail

Outputs

Twelve Form-C relay outputs: 2 A @ 30 VDC resistive

Certifications

UL 294 and UL1076 recognized
CE compliant
FCC Class A ICES-003

Dimensions (L x W x H)

6.46 x 5.51 x 1.02" (16.4 x 14.0 x 2.6 cm)

Temperature

32°F to 158°F (0°C to 70°C) (operational)
-67°F to 185°F (-55°C to 85°C) (storage)

Operating humidity

5% to 85% (non-condensing) RH

Warranty

Alarm.com warrants the product is free from defects in material and workmanship under normal use and service with proper maintenance for one year from the date of factory shipment. Alarm.com assumes no responsibility for products damaged by improper handling or installation. This warranty is limited to the repair or replacement of the defective unit.

There are no expressed warranties other than set forth herein. Alarm.com does not make, nor intends, nor does it authorize any agent or representative to make any other warranties, or implied warranties, and expressly excludes and disclaims all implied warranties of merchantability or fitness for a particular purpose.

Returns must be accompanied by a Return Material Authorization (RMA) number obtained from customer service, and prepaid postage and insurance.

Liability

The Interface should only be used to control exits from areas where an alternative method for exit is available. This product is not intended for, nor is rated for operation in life-critical control applications. Alarm.com is not liable under any circumstances for loss or damage caused by or partially caused by the misapplication or malfunction of the product. Alarm.com's liability does not extend beyond the purchase price of the product.



This device complies with part 15 of the FCC Rules. Operation is subject to the following two conditions:

- (1) This device may not cause harmful interference, and
- (2) this device must accept any interference received, including interference that may cause undesired operation.



8281 Greensboro Drive
Suite 100
Tysons, VA 22102

210406
© 2021 Alarm.com. All rights reserved. Designed in the USA. Made in USA.